

ICE - ROUND CRANE MODELS

ROUND-UP



YELLOW SUBMARINE



ROUND-UP



OWNERS AND SERVICE MANUAL INNOVATIVE CONCEPTS IN ENTERTAINMENT INC.

10123 MAIN STREET, CLARENCE, NY 14031

SERVICE: 1-716-759-0360

FAX: 1-716-759-0884

E-MAIL: service@icegame.com

WEBSITE: www.icegame.com

TABLE OF CONTENTS

INTRODUCTION.....	PAGE 3
• GAME FEATURES	
• GAME PLAY	
SET-UP / TESTING / MAINTENANCE.....	PAGE 4
• SAFETY PRECAUTIONS	
• GAME SET-UP	
• ASSEMBLY	
• TESTING	
• CLEANING	
PROGRAMMING.....	PAGE 5 & 6
• OPTION MODES	
• ERROR CODES	
QUICK TROUBLESHOOTING.....	PAGE 7 & 8
• PROBLEMS AND SOLUTIONS	
PARTS LISTINGS.....	PAGE 9 & 10
SCHEMATICS.....	PAGE 11 - 15
WIRING DIAGRAMS.....	PAGE 16 - 36
WARRANTY INFORMATION.....	PAGE 37 & 38

INTRODUCTION

GAME FEATURES

The new ROUND CRANE by I.C.E. was designed with the operator in mind. Reliability, low maintenance, available custom cabinetry, and all metal exterior construction are some of the most important design features to be added to the newest member of our crane family.

To keep things easy for the operator, all of our best features have been carried over from our other designs. Things such as an all-metal exterior, powdered epoxy paint, tempered glass windows, and full-featured programming are standards you've come to expect from I.C.E. products.

The ROUND CRANE uses state of the art electronics with a new drive circuit for all motors. In our new design, even direct short circuits can't damage the motor or coil drivers. The protection is built into the drivers themselves! Another advantage is that the new board incorporates modular driver circuits so the same main board can be used on multiple products.

This crane has been made to give you a crane that is competitive with other smaller cranes of similar size, but it has been engineered to leave the competition behind. The ROUND CRANE has been designed to easily go through a 36" door without disassembly, and it is made to be a great centerpiece type of game. Great for Mall and arcade type locations.

We hope you thoroughly enjoy your ownership experience with your new ROUND CRANE. If you have any questions or comments, please contact our service department at: (716) 759-0360

GAME PLAY

As coins are inserted into the ROUND CRANE a coin in sound will be heard. When sufficient coins have been inserted, the game sound starts, the claw clicks closed and re-opens, which signals the start of the game. The crane will position its self in the middle of the "play field" and remain there, with the cranes sound theme playing until the player is ready.

When the player has moved the joystick or pressed the buttons, to move the crane, the timer on the right display will begin to count down. The player will position the crane above the prize and they are attempting to win and press the drop button to lower the claw.

If the nudging option is on, then the player will have the ability to keep "nudging" the claw down each time the button is pressed to hone in on the chosen prize. If the nudging option is off, then the player will have only one chance to drop the claw.

When the claw is fully dropped it will close and retract to its upper most position. The crane will then automatically position its self over the prize chute at the rear of the cabinet. The claw will open, releasing the prize (if grabbed) into the prize chamber. The player can now remove the prize from the chamber through the prize door located in the front of the game. The game is now in its home position and is ready for the next player in line.

SET-UP / TESTING / MAINTENANCE

SAFETY PRECAUTIONS

IMPORTANT: FAILURE TO FOLLOW THESE DIRECTIONS CLOSELY COULD CAUSE SERIOUS DAMAGE TO YOUR GAME.

WARNING: WHEN INSTALLING THIS GAME, A 3 PRONG GROUNDED RECEPTACLE MUST BE USED. FAILURE TO DO SO COULD RESULT IN SERIOUS INJURY TO YOURSELF OR OTHERS. FAILURE TO USE A GROUNDED RECEPTACLE COULD ALSO CAUSE IMPROPER GAME OPERATION, OR DAMAGE TO THE ELECTRONICS.

DO NOT DEFEAT OR REMOVE THE GROUNDING PRONG ON THE POWER CORD FOR THE SAME REASONS AS GIVEN ABOVE. USING AN IMPROPERLY GROUNDED GAME COULD VOID YOUR WARRANTY.

GAME SET-UP

BEFORE PLUGGING THE GAME IN, OR TURNING IT ON, BE SURE THE GAME HAS BEEN SET TO THE PROPER VOLTAGE. YOUR GAME SHOULD COME PRE-SET FROM THE FACTORY CORRECT VOLTAGE, HOWEVER IT IS A GOOD IDEA TO CHECK THE A.C. WALL RECEPTACLE VOLTAGE BEFORE PLUGGING THE GAME IN.

ASSEMBLY INSTRUCTIONS

1. Carefully unbox the game from its packaging.
2. Using the supplied keys, unlock the front door of the cabinet.
3. Cut all tie wraps holding the wagon assembly and crane in place.
4. Plug the game into a three prong grounded receptacle. **NOTE:** The appliance must be positioned such that the plug is accessible during use.
5. The game is now ready for start up.

TESTING

After the initial setup, it is time to test your game for proper operation.

1. Locate the game in its permanent location.
2. Be sure the game has been properly plugged into a 3 prong grounded outlet, and that the receptacle is in good working order.
3. If using an extension cord, be sure it is a 3 prong grounded type of at least 16Ga.
4. Verify that the game is set up for the proper voltage, and turn the power to the game on.
5. The game will run through a test mode at every startup. See test mode explanation in the programming section for details.
6. Insert coins/bills into the machine at least ten times into the coin mech/bill acceptor to assure proper operation
7. Check the credit and prize counters for proper operation.
8. Check game volume during busy time at location to set it at the proper level.

CLEANING

Regular cleaning of this game will keep it looking new, and greatly enhance its appeal.

Clean the windows of your ROUND CRANE with a standard window cleaner such as Windex®

Clean the cabinet sides with a good cleaner such as "Fantastic" or "409" and a soft rag. A mild soapy solution can be used. You may use a furniture polish when finished to protect the game and make it look more attractive,

NOTE: DO NOT USE ALCOHOL, THINNERS OF ANY KIND, OR PINBALL PLAY FIELD CLEANERS ON ANY OF THE CABINET SURFACES ESPECIALLY THE DECALS.

IF YOU HAVE ANY QUESTIONS OR COMMENTS REGARDING INSTALLATION OR PROPER FUNCTION OF YOUR GAME, PLEASE CALL OUR SERVICE DEPARTMENT AT
1-716-759-0360

PROGRAMMING

<u>MODE</u> (Credit Display)	<u>DESCRIPTION</u>	<u>MIN / MAX / DEF</u> (Timer Display)	<u>MEANING</u>
<u>BASIC PROGRAMMING</u>			
0	Game Type	0, 1, 0	0—Left, Right, Forward, Backward, Nudge 1—Left, Right, Forward, Backward, Drop
1	Game Mode	0, 1, 0	0—Normal Play 1—Play till you win
2	Time	10, 60, 20	10—60 Seconds (Inc. every 1 second)
3	Coin	0, 9, 2	0—Free Play 1—9 Coins required for a single credit
4	Bill	0, 9, 4	0—Off 1—9 Number of coins each bill is worth
5	Counter Type	0, 1, 0	0—Credit counter 1—Coin counter
6	Attract	1, 30, 20	1—30 Minutes between attract modes
7	Attract Type	1, 2, 2	1—Motion only 2—Audio and motion
8	Manual Strength	40, 99, 75	40—99 Claw strength Inc. by 1 (99= MAX)
<u>ADVANCED PROGRAMMING</u>			
9	Auto Skill Leveling Strength	0, 99, 0	0—Auto off 60—99 Claw strength in auto (99 = MAX)
10	Right Time	0, 9, 5	0—40 Number of 1/4 sec. time intervals right
11	Forward Time	0, 40, 5	0—40 Number of 1/4 sec. time intervals forward
12	Plush Cost	1, 20, 4	Coins per piece of plush
13	Payout	20, 50, 33	20—50 Desired payout percentage
14	Tickets to Play	0, 99, 0	0—99 tickets to be paid just to play game
15	Tickets if Lose	0, 99, 0	0—99 tickets to be paid if you do not win plush
16	Factory Default	0, 1, 0	0—Normal 1—Restore factory defaults upon next startup
17	Center On / Off	0, 1, 0	0—Center option off 1—Center option on
18	Snap On / Off	0, 1, 1	0—Snap option off 1—Snap option on
19	Credit Discounting	0, 5, 0	# of Consecutive credits inserted for 1 free game
20	Up / Down Motor Test	DIAG.	Right display changes: 0 – 1 Up switch is made 0 – 2 Down switch is made 0 – 3 Both switches are made
21	Left / Right Motor Test	DIAG.	Right display changes: 0 – 1 Left switch is made
22	Front / Back Motor Test	DIAG.	Right display changes: 0 – 1 Back switch is made 0 – 2 Front switch is made

PROGRAMMING

Error Codes

<u>#</u>	<u>Problem</u>
1	E ² (Memory)
2	Prize Sensor
3	Up Sensor
4	Down Sensor
5	Left
6	NOT USED
7	Right
8	Back
9	Front
10	Counter Disconnect
11	Out Of Range (High)
12	Out Of Range (Low)

QUICK TROUBLESHOOTING

PROBLEM	PROBABLE CAUSE	SOLUTION
THE DECIMALS ON THE 4 DISPLAYS ARE LIT UP	THIS IS IN FACT NOT A PROBLEM BUT A WAY OF LETTING THE OPERATOR KNOW THAT THERE WAS A PROBLEM DURING THE START UP MODE	OPEN THE FRONT DOOR AND THE ERROR CODES ARE SHOWN ON THE DISPLAYS. TO ADVANCE THROUGH THE ERROR CODES, PRESS THE FIRE BUTTON
NO GAME POWER	ON-OFF SWITCH ON THE GAME IS TURNED OFF BLOWN A.C. POWER FUSE GAME NOT PLUGGED OR CORD DAMAGED BAD TRANSFORMER TRANSFORMER HARNESS NOT CONNECTED BAD POWER MODULE	TURN POWER ON REPLACE WITH PROPER FUSE CHECK POWER CORD CHECK FOR PROPER VOLTAGES CHECK HARNESS REPLACE POWER MODULE
GAME WILL NOT TAKE MONEY OR GIVE CREDITS CORRECTLY	BAD COIN SWITCH COIN DISCOUNTING SET WRONG COINS PER CREDIT SETTING INCORRECT BAD COIN MECHANISM LOOSE OR DAMAGED HARNESSING BAD MAIN P.C. BOARD	CHECK W/METER AND REPLACE CHECK PROGRAMMABLE SETTING CHECK PROGRAMMABLE SETTING ADJUST OR REPLACE CHECK W/METER - REPAIR REPAIR OR REPLACE MAIN BOARD
DISPLAYS DO NOT WORK	BAD 12V FUSE BAD DISPLAY P.C. BOARD BAD MAIN P.C. BOARD LOOSE OR DAMAGED DISPLAY HARNESSING	REPLACE WITH PROPER FUSE REPAIR OR REPLACE P.C. BOARD REPAIR OR REPLACE P.C. BOARD CHECK W / METER AND REPAIR
CRANE OR WAGON DOES NOT MOVE	BAD MOTOR LOOSE OR DAMAGED HARNESSING BAD SWITCH ON BUTTON OR JOYSTICK BAD HARNESSING TO BUTTONS OR JOYSTICK BLOWN FUSE TO MOTORS ON MAIN P.C.B. BROKEN DRIVE BELT	REPLACE MOTOR CHECK W / METER - REPAIR REPLACE SWITCH CHECK W / METER - REPAIR REPLACE WITH PROPER FUSE REPLACE BROKEN BELT
CRANE KEEPS TRYING TO MOVE IN TO THE HOME POSITION	BAD LIMIT SWITCH(S) LIMIT SWITCH NOT ALIGNED WITH ACTUATOR	REPLACE SWITCH(S) ALIGN SWITCH AND ACTUATOR
CLAW WILL NOT CLOSE	BLOWN FUSE TO CLAW ON MAIN P.C. BOARD BAD COIL LOOSE OR DAMAGED HARNESSING CLAW HAS MECHANICALLY JAMMED	REPLACE WITH PROPER FUSE REPLACE COIL CHECK W / METER AND REPAIR FIND JAM AND REPAIR
CLAW STAYS CLOSED	BAD DRIVE TRANSISTOR ON MAIN P.C.B. CLAW HAS MECHANICALLY LOCKED	REPLACE TRANSISTOR FIND JAM AND REPAIR
AUTO PERCENTAGING IS NOT FUNCTIONING	PROGRAMMING IS NOT CORRECTLY SET BAD PRIZE SENSOR LOOSE OR DAMAGED SENSOR HARNESS CLAW SLIDER SET IMPROPERLY	SET OPTIONS "9" AND "16" REPLACE PRIZE SENSOR CHECK W / METER AND REPAIR ADJUST SLIDER
CLAW GOES DOWN AND THEN UP BUT DOES NOT CLOSE	DOWN SWITCH BAD LOOSE OR DAMAGED HARNESS TO DOWN SWITCH	REPLACE DOWN SWITCH CHECK W / METER AND REPLACE
CLAW COMES UP AND ABOUT 15 SEC. PASSES BEFORE CRANE MOVES TO THE HOME POSITION	UP SWITCH BAD LOOSE OR DAMAGED HARNESS TO UP SWITCH	REPLACE UP SWITCH CHECK W / METER AND REPLACE
CRANE OR WAGON WHEELS SLIP	LOOSE SET SCREWS IN WHEELS LOOSE SET SCREWS IN DRIVE COUPLER RAILS NEED TO BE SCUFFED	TIGHTEN SET SCREWS TIGHTEN SET SCREWS SCUFF TOP OF RAILS WITH SANDPAPER

QUICK TROUBLESHOOTING

1. A self-test will be performed each time the front door is “closed” or the game is powered up.
2. If the Wagon does not move smoothly through a full travel from SIDE to SIDE, check to see that the motor driver board is working properly, and that the rotary motor itself is working.
3. If the Wagon does not move smoothly through a full travel from front to back, check to see that the rod bushings are straight and not binding. Check for excessively loose drive belts or one of them broken.
4. If the front door is having trouble closing fully, check to see that the front door harness is routed properly. Also be sure the prize door is fully shut. If it is partially open it will not allow the front door to open or close properly.
5. If the door will not lock properly or locks with difficulty, check to see if the lock rotates smoothly. Next check that the lock rods are not binding on the lock cam or the lock rod guides. Next check that all friction points have been lubricated with molly grease. Finally if need be, file the lock rod guides such that the door closes and locks smoothly but be careful not to file out too much, for this may cause the door not to pull tightly to the cabinet as it was intended to do. Adjust the lock rod striker plates if necessary.
6. If the decimals light up on the displays after a self-test, an error has been locked. To advance through the error codes press the drop button when in error detection mode.
7. If, at the beginning of the self-test mode, the claw does not drop, one or more of the following may apply. The prize sensor is not working, or blocked. The string or string lever is mechanically binding. The up or down switch is sticking or misaligned from its actuator.
8. If claw stays closed it is likely that the diode has blown and the transistor controlling the claw has also blown. Shut off the game immediately and have a new diode, in coil assembly, and transistor, on main board, installed.
9. If claw is jerky while being lowered, it is likely that the string has mechanically bound on the spool. To fix the string binding enter programming mode and go to CLAW UP/DOWN MODE. By moving the joystick to the left and right you are able to raise and lower the claw mechanism. Move the crane over the prize chute and lower the claw mechanism all the way until it starts to wind up backwards. Reverse the motor direction to raise the claw mechanism and properly rewind the string on the spool. Exit the programming mode and the string should be free of mechanical binding.
10. If the claw stays open First check for bad fuses on the main board, next check that there are no wires dislodged from the connectors in the harness between the wagon and the crane, the harness between the wagon and the main board, the crane assembly and the wagon assembly. If the problem still exists and no fuses are blown or wires dislodged it is likely that the transistor controlling the voltage to the claw has blown on the main board. Replace main board and have the other main board repaired by electronics.
11. If the crane/wagon in the home position still tries to move left or back, check to see that the actuators are both present. Check to see that the sensors are present. Next check to see that the sensors and the actuators are both aligned. Then check to see that the sensor wires are not dislodged from the connectors. Finally replace the sensor; it is likely to be bad.

PARTS LISTINGS

MECHANICAL PARTS

1030	Dollar Bill Validator Cover Plate
3004	Spacer, Long
3051	Wheel "O" Ring
5011	Spring
5014	Cash Box Lock
5101X	Coin Mech Holder Assembly
BB3022	Wheel
BC1013-P801	Lock Cam
CG1052	Swivel Caster
CG1054	Wagon Roller Shaft
CG1061X	Crane Assembly
CG1062	Crane motor Housing Cover
CG1066	Crane UP Spring
CG1070	Coil Housing
CG1073	Coil Slider
CG1075	Coil Plunger
CG1078A	Small Claw
CG1078B	Medium Claw
CG1078BX	Medium Claw Assembly w / Solenoid
CG1078D	Jumbo Claw
CG2039X	Prize Sensor
CG3008A	Micro Track Link
CG3008B	Micro Track End Set
CG3019	Thumb Screw
CG3030	Wheel
CG3036	Coil / Claw Interconnect
CG3037	Claw Spider
CG4003	O-Ring Drive Band
CG4004	Spring
CG5014	"T" Handle Lock
CP1038-P801	Prize Door Hinge
RC1003-P700	Playfield Hinge
RC1012	Cash Box
RC1018-P100	Podium
RC1026-P100	Door Hinge
RC1022	Rotary Motor Coupler Assembly
RC1052	3" Swivel Caster
RC1061	Wheel Spacer
RC1062	Wheel Cap
RC3001AX	Dome Assembly
RC3008A	Micro Track Special Link ("S" bend)
RC3027	Window, Front
RC3028	Window, Side
RC3067	Prize Door
SR1053	Magnet

ELECTRONIC / ELECTRICAL

2033X	Controller Board
2089X	AC Rope Light Harness
2133CW	White Chase Style Rope Light
2133U	Rope Light "U" Channel
2134	Rope Light End Cap
2134A	Chase light Power cord
8312	PLL Florescent Light Bulb
BC2032X	Display, P.C. Board Assembly
BW2017	Light Bulb Retaining Clip
BW2018	Light Bulb Retainer
CG2008	Motor / Gearbox
CG2014	Joystick
CC2027	20 Ft. Power Cord, Computer Style
CG2012	Front / Back Sensor
CG2013	Left / Right Sensor
CG2039X	Prize Sensor
CG2014	4 Way Joystick w / Push Button
CS2002X	Transformer
CS2007X	Power Module Assembly
FP2007	4" Round Speaker
HH1020	Actuator, Home Position
PP250X	PLL Light Socket
RC2008	Rotational Motor and Gearbox Assy.
RC2029X	Motor Driver Board
RC2034X	Main P.C. Board
RC2035X	Rotary Motor Driver Board
RC2036X	Rotary Harness Adapter Board
RC2535X	Strobe Light Assembly
MZ8284X	Ballast, Work Horse 6

SUB CRANE ONLY

1017	L.E.D. Holder
RC2035X	Strobe Light Assembly
RC3501X	Yellow Sub Dome Assembly
RC3529X	Porthole Side Panel Insert Assembly
RC3530	Diving Bell Claw Assembly
RC3530AX	Diving Bell Top Assembly
RC3531AX	Diving Bell Bottom Assembly
RC3540X	Periscope Mount Assembly
RC3542X	Left Large Periscope Assembly
RC3543X	Right Large Periscope Assembly
RC3545X	Small Periscope Assembly

PARTS LISTINGS

GRAPHICS

ROUND UP CRANE

RC7001	Prize Door Decal
RC7012	Control Panel Overlay
RC7027	Front Marquee Cabinet Decal
RC7028	Side Marquee Cabinet Decal

YELLOW SUBMARINE CRANE

RC7500	Cabinet Right Side Decal
RC7501	Prize Door Decal
RC7502	Cabinet Left Side Decal
RC7503	Window Rounds
RC7504	Rivet Bar, Right
RC7505	Rivet Bar, Left
RC7506	Diving Bell Top
RC7508	Cabinet Front
RC7509	Diving Bell Bottom
RC7512	Control Panel Overlay
RC7527	Front Marquee Cabinet Decal
RC7528	Side Marquee Cabinet Decal
RC7533	Bubbles, Small
RC7534	Bubbles, Small
RC7542	Green Rivets
RC7543	Yellow Rivets
RC7545	Red Rivets

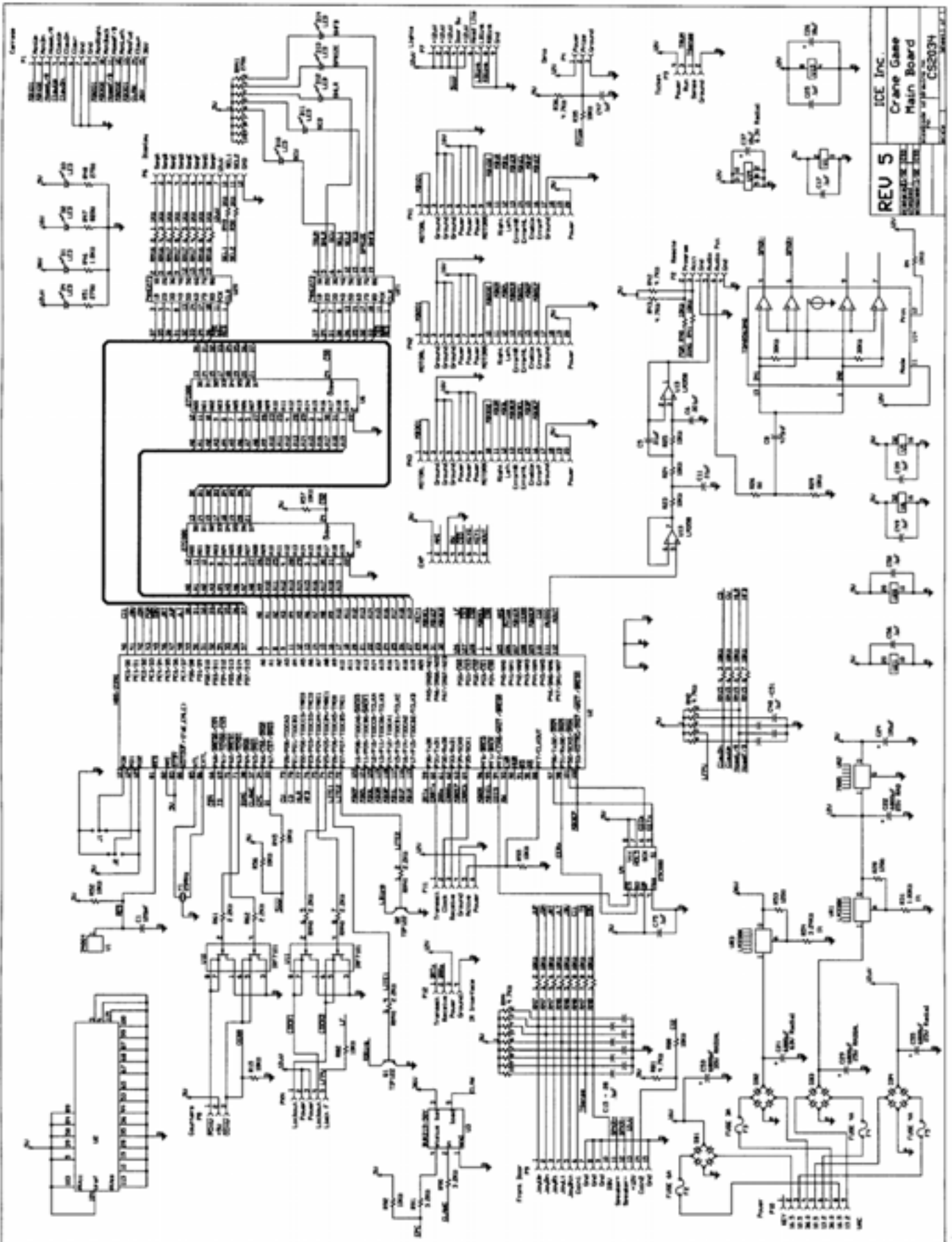

REV 5
ICE Inc.
Crane Gate
Main Board
CS203H

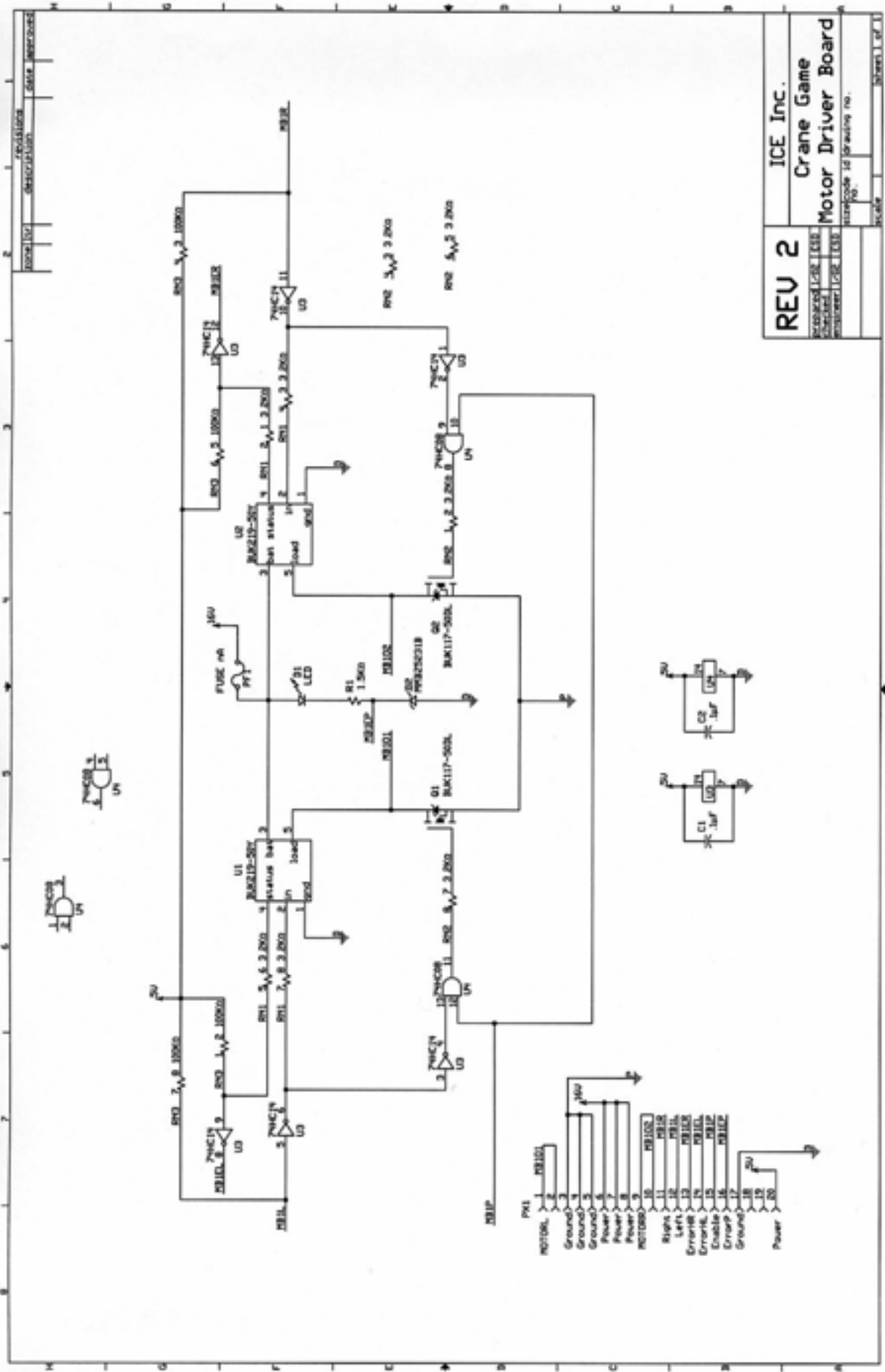

REV 2		ICE Inc.	
PROPOSED	DATE	Crane Game	
DESIGNED	DATE	Motor Driver Board	
CHECKED	DATE	Manufacture to drawing no.	
APPROVED	DATE	Scale	
		Sheet 1 of 1	

zone	tr	description	revisions	date	approved

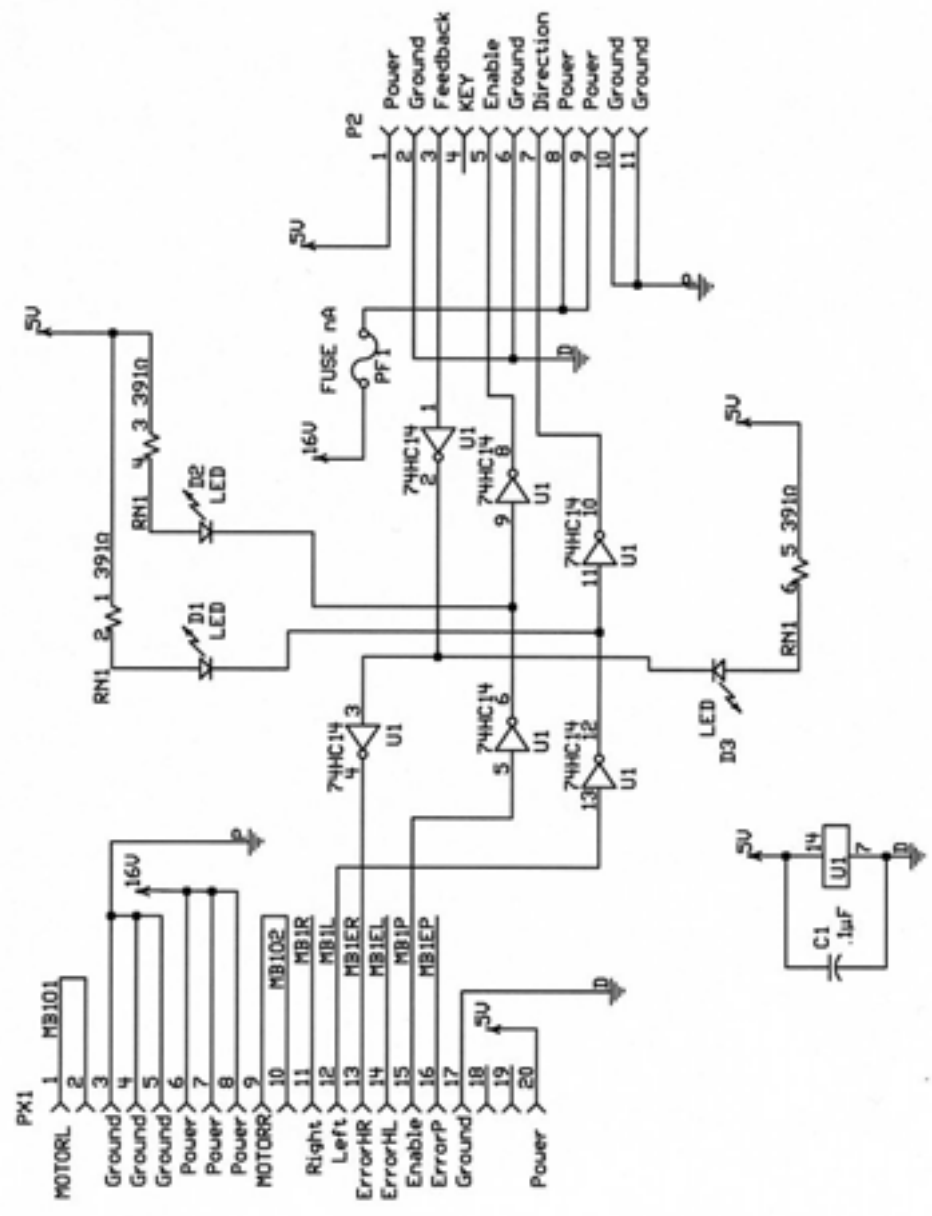

REV 2		ICE Inc.	
		Crane Game	
		Round Driver Intfc	
prepared	1/02	ESD	
checked			
engineer	1/02	ESD	
size/code id		drawing no.	
scale		sheet 1 of 1	

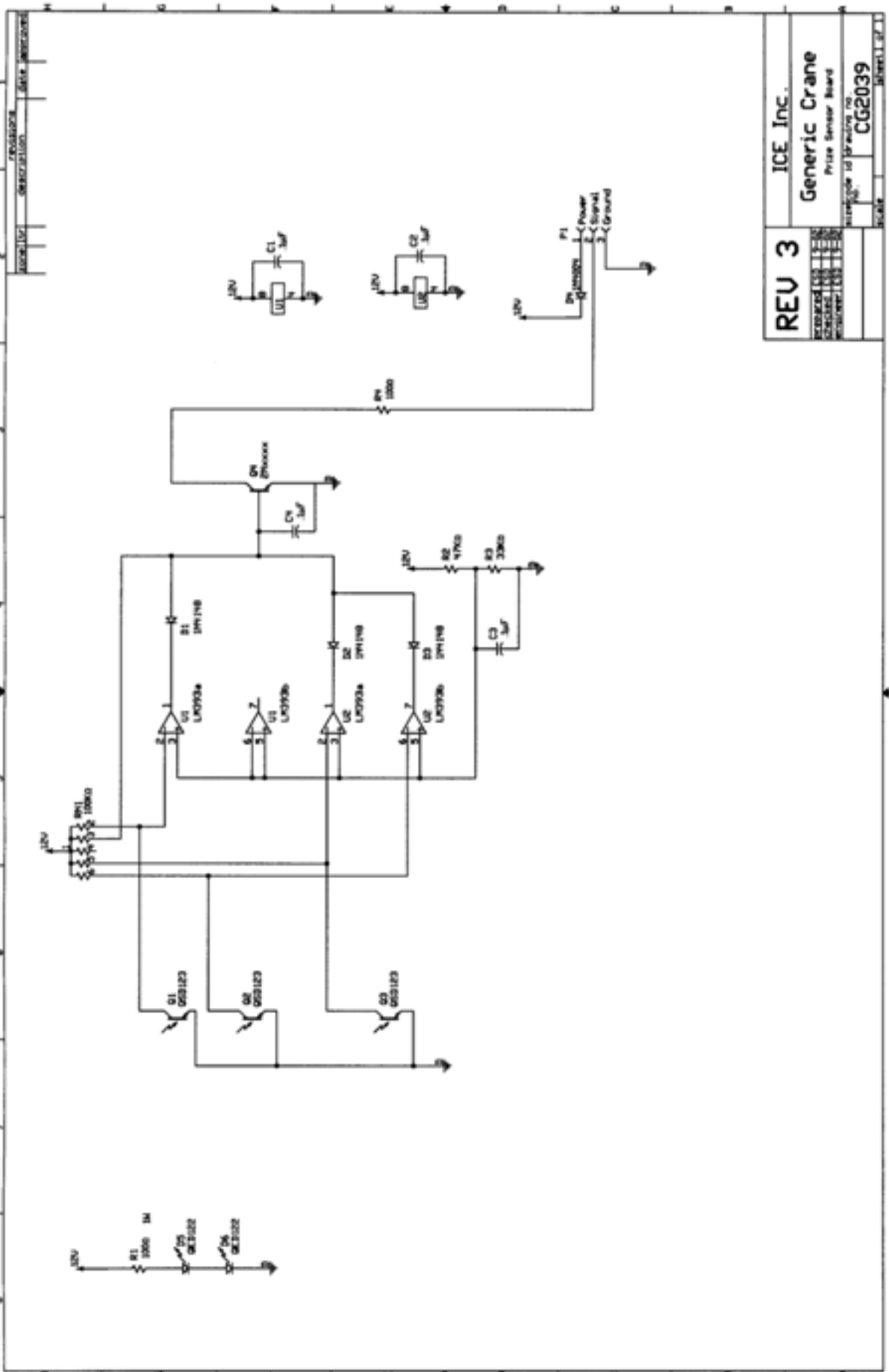

REV 3	REVISED BY	ICE Inc.
	DATE	
DESCRIPTION		Generic Crane
PARTS LIST		Price Sensor Board
REVISIONS		Quantity of Drawing no.
		CG2039
		SCALE
		SHEET 1 OF 1

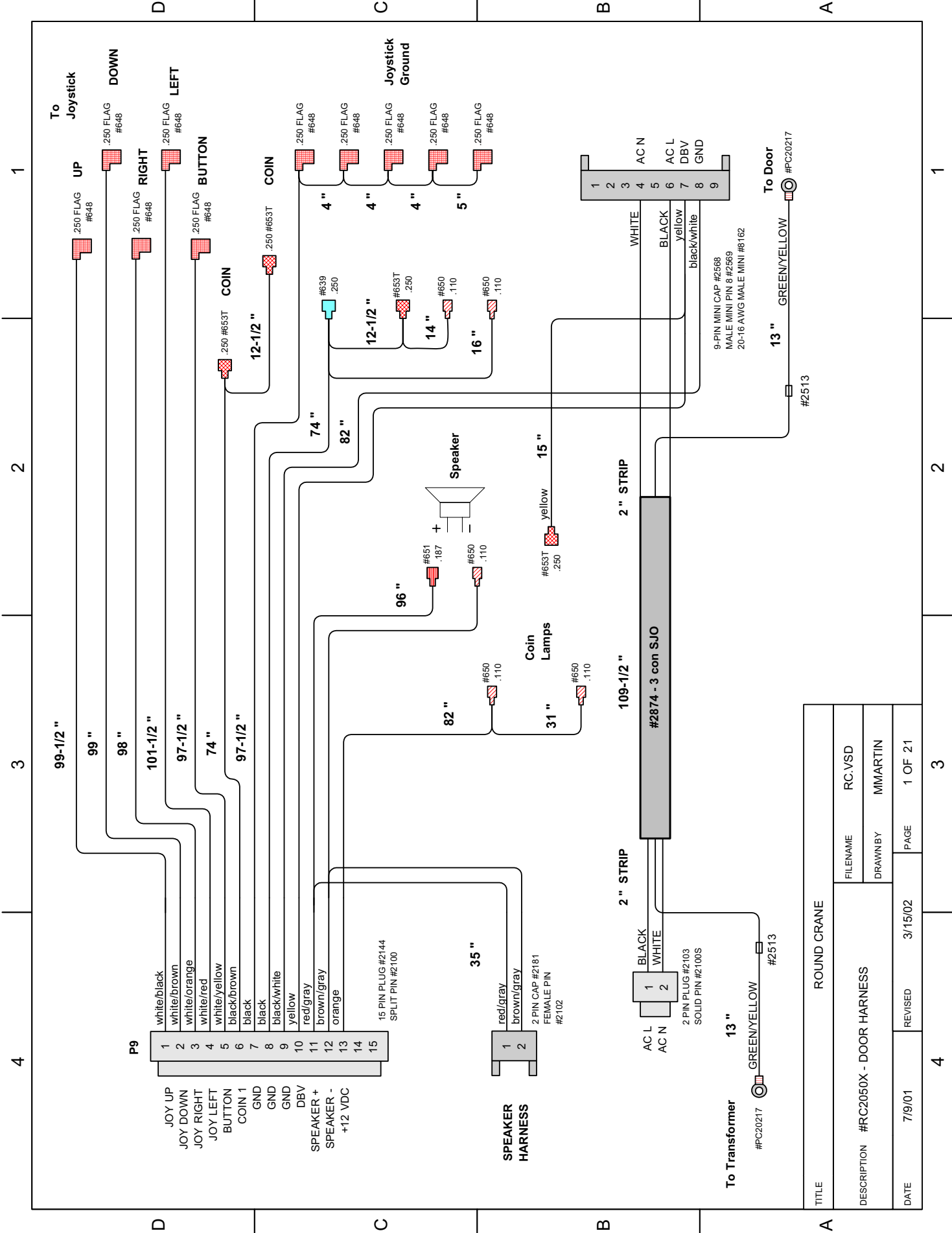

TITLE		ROUND CRANE	
DESCRIPTION		FILENAME	RC.VSD
DATE		DRAWN BY	MMARTIN
7/9/01	REVISED	PAGE	1 OF 21
	3/15/02		

1 2 3 4

D C B A

#RC2051X - SENSOR HARNESS

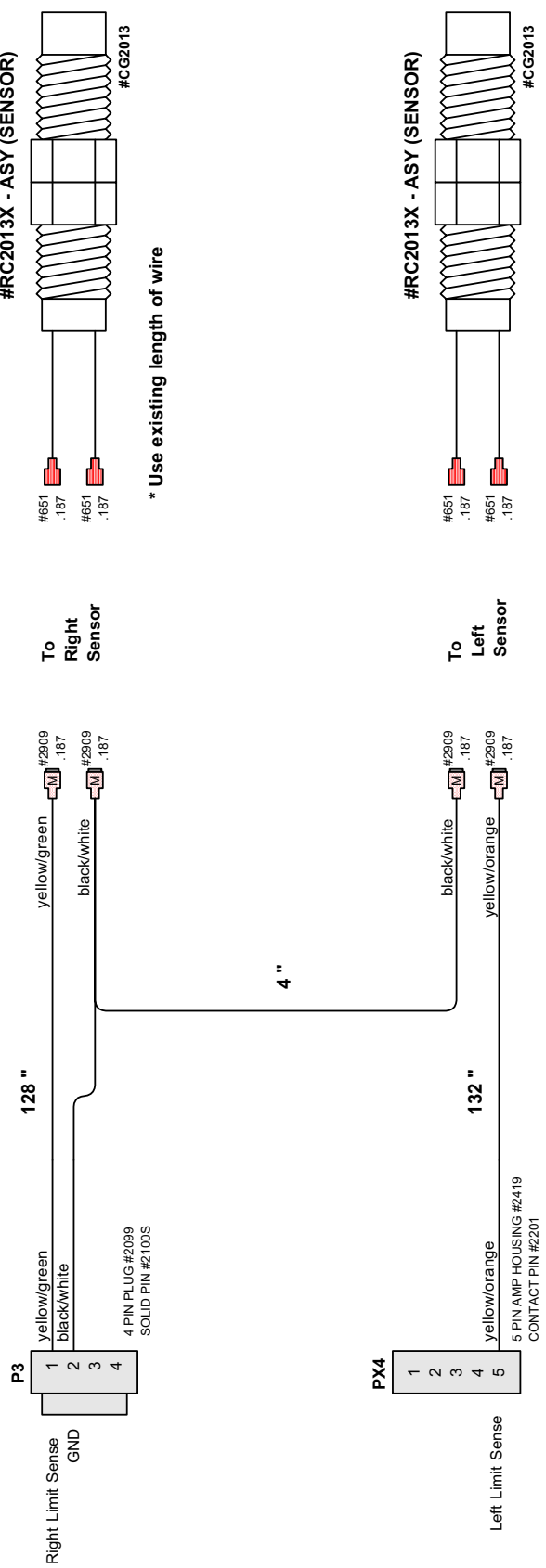

* Use existing length of wire

* Use existing length of wire

* Twist together 132 " cut 4 " off yellow/
green and black/white on P3 end
Use the 4 " of black/white for jumper in
harness

TITLE	ROUND CRANE		
DESCRIPTION	#RC2051X - SENSOR HARNESS #RC2013X - ASY (SENSOR)	FILENAME	RC.VSD
DATE	7/9/01	DRAWNBY	MMARTIN
	REVISED	3/15/02	PAGE 2 OF 21

1 2 3 4

1 2 3 4

D C B A

D C B A

To Main To Rotary Harness

To Wagon Harness

NOT TWISTED

36"

1	Motor Up
2	Motor Down
3	Home L/R
4	Claw Up
5	Claw Down
6	Claw -
7	Ground
8	Motor Bk
9	Home F/B
10	Motor Fd
11	Claw +
12	EARTH

1	Motor Up
2	Motor Down
3	Home L/R
4	Claw Up
5	Claw Down
6	Claw -
7	Ground
8	Ground
9	Motor Bk
10	Home F/B
11	Motor Fd
12	Claw +
13	EARTH
14	EARTH
15	EARTH

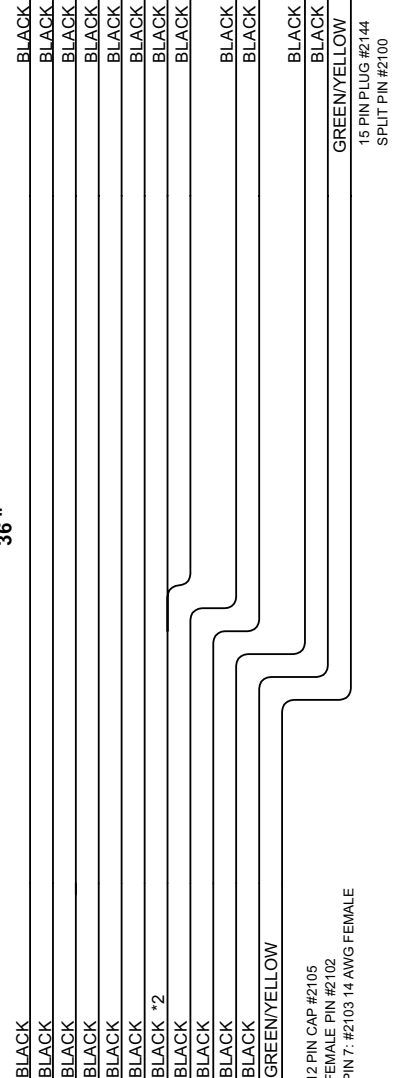

12 PIN CAP #2105
 FEMALE PIN #2102
 PIN 7: #2103 14 AWG FEMALE

GREEN/YELLOW
 15 PIN PLUG #2144
 SPLIT PIN #2100

TITLE		ROUND CRANE	
DESCRIPTION		#RC2052AX - ROTARY HARNESS	
DATE	7/9/01	REVISED	3/15/02
FILENAME		RC.VSD	
DRAWN BY		MMARTIN	
PAGE		3 OF 21	

1 2 3 4

1 2 3 4

D C B A

MAIN TO ROTARY HARNESS

TO MAIN PCB CARRAGE P1

3" STRIP 142" #2997-2 CONDUCTOR POWER CORD 3" STRIP

- 1 Motor Up
- 2 Motor Down
- 6 Motor Down Claw -
- 9 Motor Bk
- 10 Motor Lt
- 12 Motor Fd
- 13 Motor Fd Claw +
- 14 Home L/R
- 3 Claw Up
- 4 Claw Down
- 5 Ground
- 7 Ground
- 8 Home F/B
- 11 36v
- 15 15 PIN PLUG #2144 SPLIT PIN #2100

- 1 Motor Up
- 2 Motor Down
- 8 Motor Bk
- 10 Motor Fd
- 12 EARTH
- 6 Claw -
- 3 Home L/R
- 4 Claw Up
- 5 Claw Down
- 7 Ground
- 11 Claw +
- 9 Home F/B
- 12 PIN PLUG #2106 SPLIT PIN #2100

142" TWISTED WIRE
 -12" GREEN/YELLOW TO FRAME #652

142" TWISTED WIRE
 * Untwist GREEN/YELLOW 21"
 Cut Off 12" of GREEN/YELLOW (P1 end)

TITLE		ROUND CRANE	
DESCRIPTION	#RC2052X - MAIN/ROTARY HARNESS	FILENAME	RC.VSD
DATE	7/9/01	DRAWN BY	MMARTIN
REVISED	3/15/02	PAGE	4 OF 21

1 2 3 4

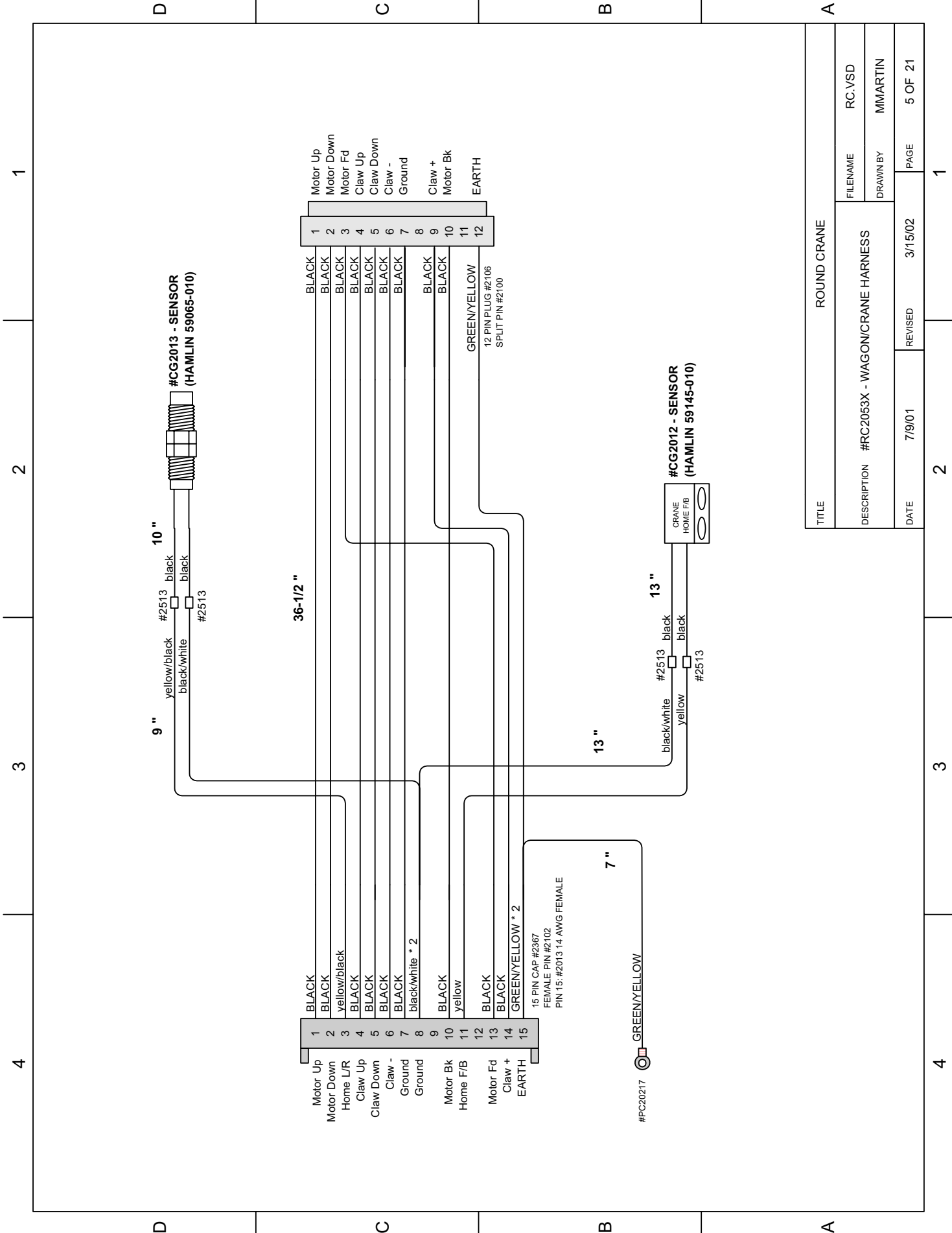

#CG2013 - SENSOR
(HAMLIN 59065-010)

#CG2012 - SENSOR
(HAMLIN 59145-010)

- 1 Motor Up
- 2 Motor Down
- 3 Motor Fd
- 4 Claw Up
- 5 Claw Down
- 6 Claw -
- 7 Ground
- 8
- 9 Claw +
- 10 Motor Bk
- 11 EARTH
- 12

- 1 BLACK
- 2 BLACK
- 3 yellow/black
- 4 BLACK
- 5 BLACK
- 6 BLACK
- 7 BLACK
- 8 black/white * 2
- 9 BLACK
- 10 yellow
- 11 BLACK
- 12 BLACK
- 13 GREEN/YELLOW * 2
- 14
- 15

15 PIN CAP #2367
FEMALE PIN #2102
PIN 15: #2013 14 AWG FEMALE

TITLE		ROUND CRANE	
DESCRIPTION	#RC2053X - WAGON/CRANE HARNESS	FILENAME	RC.VSD
DATE	7/9/01	DRAWN BY	MMARTIN
REVISED	3/15/02	PAGE	5 OF 21

4 3 2 1

D C B A

DISPLAY

P6

1	brown
2	red/black
3	orange/black
4	yellow
5	green
6	blue
7	ORANGE
8	gray
9	white
10	black/white
11	tan
12	BLACK

12 PIN PLUG #2106
SPLIT PIN #2100

TO MAIN PCB

99 "

P1

1	brown
2	red/black
3	orange/black
4	yellow
5	green
6	blue
7	ORANGE
8	gray
9	white
10	black/white
11	tan
12	BLACK

12 PIN PLUG #2106
SPLIT PIN #2100

TO DISPLAY PCB

D C B A

TITLE

ROUND CRANE

DESCRIPTION #RC2054X - MAIN/DISPLAY HARNESS

FILENAME RC.VSD

DRAWN BY MMARTIN

DATE 7/9/01

REVISED 3/15/02

PAGE 6 OF 21

4

3

2

1

4 3 2 1

D C B A

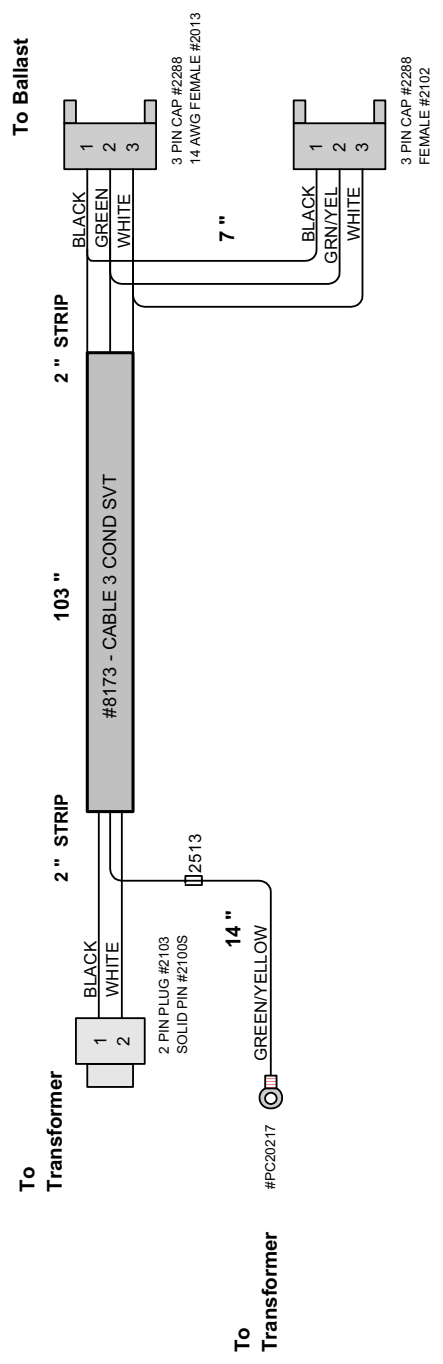

TITLE		ROUND CRANE	
DESCRIPTION		RC2057X - AC BALLAST HARNESS	RC.VSD
DATE		7/9/01	MMARTIN
REVISED		3/15/02	PAGE 7 OF 21
		2	1

1 2 3 4

D C B A

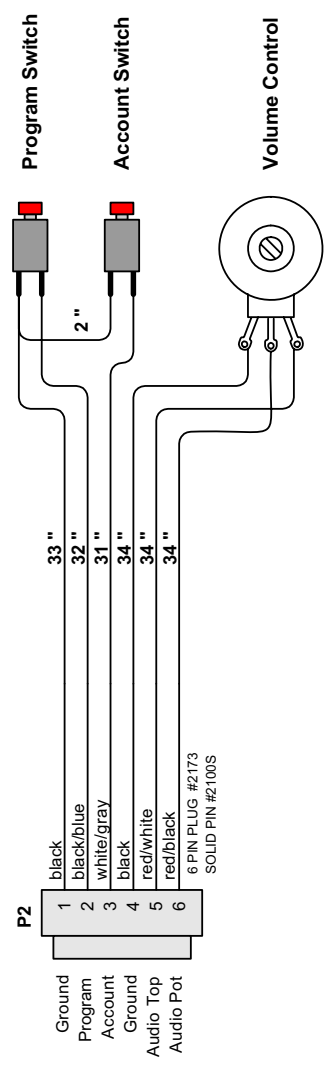

TITLE		ROUND CRANE	
DESCRIPTION		RC2059X - REMOTE HARNESS	RC.VSD
DATE		7/9/01	MMARTIN
REVISED		3/15/02	8 OF 21
PAGE		1	1

1 2 3 4

D C B A

1 2 3 4

D C B A

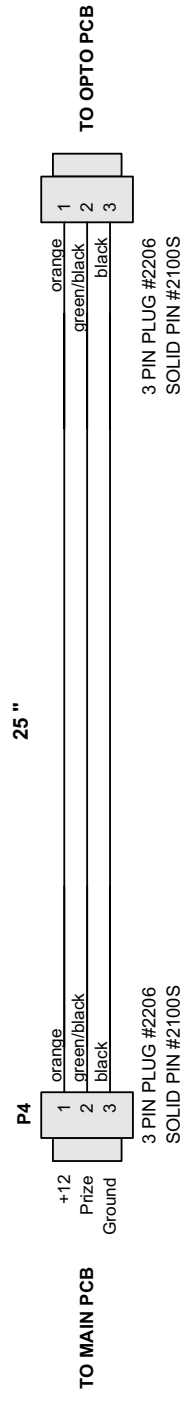

TITLE		ROUND CRANE	
DESCRIPTION	#RC2060X - OPTO HARNESS	FILENAME	RC.VSD
DATE	7/9/01	DRAWN BY	MMARTIN
		REVISED	3/15/02
		PAGE	9 OF 21

4 3 2 1

D C B A

1 2 3 4

D C B A

* USE NEW LARGE 5V COUNTERS

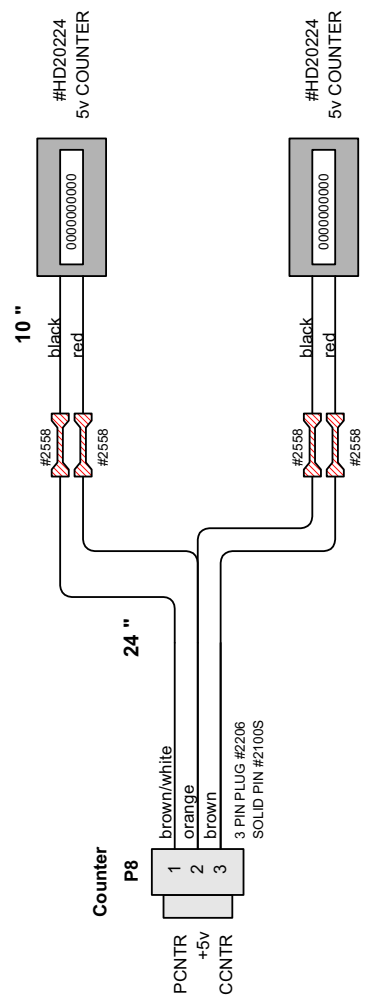

TITLE		ROUND CRANE	
DESCRIPTION		FILENAME	RC.VSD
DATE		DRAWN BY	MMARTIN
7/9/01	REVISED	3/15/02	PAGE 10 OF 21

1 2 3 4

4 3 2 1

D C B A

TO BRUSHLESS DRIVER BOARD

TO ADAPTER BOARD

P2	1	2	3	4	5	6	7	8	9	10	11
+ 5 VDC	red	black/white	white/black	KEY	white/brown	black/white	white/red	VIOLET	VIOLET	BLACK	BLACK
D GND	red	black/white	white/black	KEY	white/brown	black/white	white/red	VIOLET	VIOLET	BLACK	BLACK
Feedback	red	black/white	white/black	KEY	white/brown	black/white	white/red	VIOLET	VIOLET	BLACK	BLACK
Enable	red	black/white	white/black	KEY	white/brown	black/white	white/red	VIOLET	VIOLET	BLACK	BLACK
D GND	red	black/white	white/black	KEY	white/brown	black/white	white/red	VIOLET	VIOLET	BLACK	BLACK
Direction	red	black/white	white/black	KEY	white/brown	black/white	white/red	VIOLET	VIOLET	BLACK	BLACK
+ 24 VDC	red	black/white	white/black	KEY	white/brown	black/white	white/red	VIOLET	VIOLET	BLACK	BLACK
+ 24 VDC	red	black/white	white/black	KEY	white/brown	black/white	white/red	VIOLET	VIOLET	BLACK	BLACK
P GND	red	black/white	white/black	KEY	white/brown	black/white	white/red	VIOLET	VIOLET	BLACK	BLACK
P GND	red	black/white	white/black	KEY	white/brown	black/white	white/red	VIOLET	VIOLET	BLACK	BLACK

153 "

11 PIN AMP HOUSING #2556
CONTACT PIN #2201
KEY PLUG #2239

11 PIN AMP HOUSING #2556
CONTACT PIN #2201
KEY PLUG #2239

TITLE		ROUND CRANE	
DESCRIPTION	#RC2064X - ROTARY MOTOR DRIVER HARNESS	FILENAME	RC.VSD
DATE	7/9/01	DRAWN BY	MMARTIN
REVISED	3/15/02	PAGE	11 OF 21

4 3 2 1

D C B A

4 3 2 1

D C B A

TO FRAME #652 GREEN/YELLOW 9" GREEN/YELLOW TO TRANSFORMER #PC20217

TITLE		ROUND CRANE	
DESCRIPTION	#RC2065X - TRANSFORMER GROUND HARNESS	FILENAME	RC.VSD
DATE	7/9/01	DRAWN BY	MMARTIN
		REVISED	3/15/02
		PAGE	12 OF 21

4 3 2 1

D C B A

1 2 3 4

D C B A

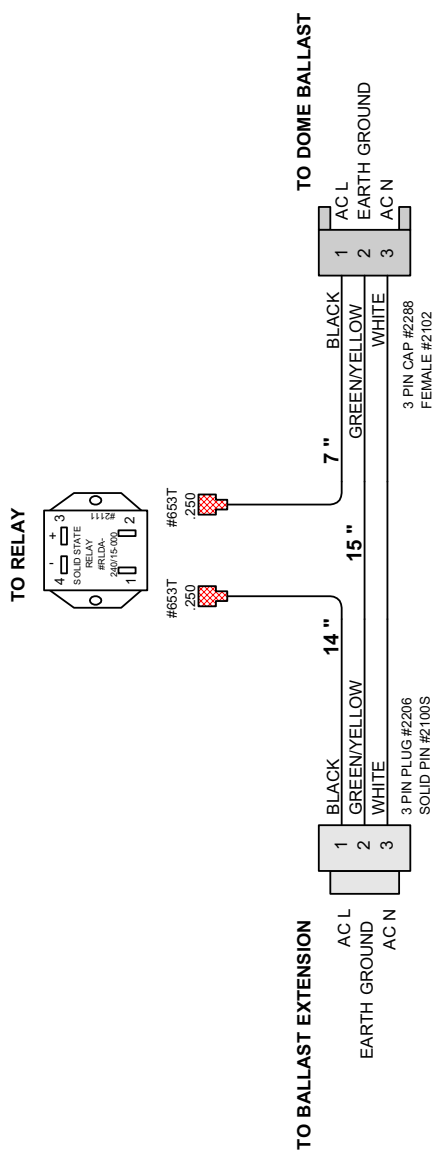

TITLE		ROUND CRANE	
DESCRIPTION	#RC2066X - BALLAST RELAY HARNES	FILENAME	RC.VSD
DATE	7/9/01	DRAWN BY	MMARTIN
		REVISED	3/15/02
		PAGE	13 OF 21

4 3 2 1

D C B A

4 3 2 1

D C B A

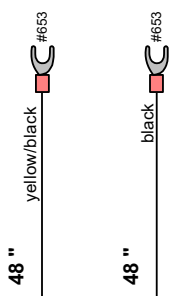
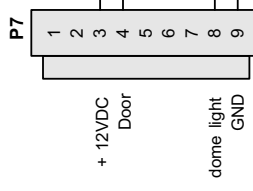

#8489 - SWITCH WIDE GAP

9 PIN PLUG #2292
SOLID PIN #2100S

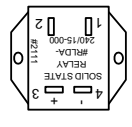

TITLE		ROUND CRANE	
DESCRIPTION		FILENAME	RC.VSD
DATE		DRAWN BY	MMARTIN
7/9/01	REVISED	3/15/02	PAGE 14 OF 21

4 3 2 1

D C B A

1 2 3 4

D C B A

To Wagon Harness

- 1
- 2
- 3
- 4
- 5
- 6
- 7
- 8
- 9
- 10
- 11
- 12
- 13
- 14
- 15

- BLACK
- BLACK
- BLACK
- BLACK
- BLACK
- BLACK
- BLACK
- BLACK
- ORANGE/BLACK
- BLACK
- BLACK/WHITE
- BLACK
- BLACK
- GREEN/YELLOW
- 15 PIN PLUG #2144
- SPLIT PIN #2100

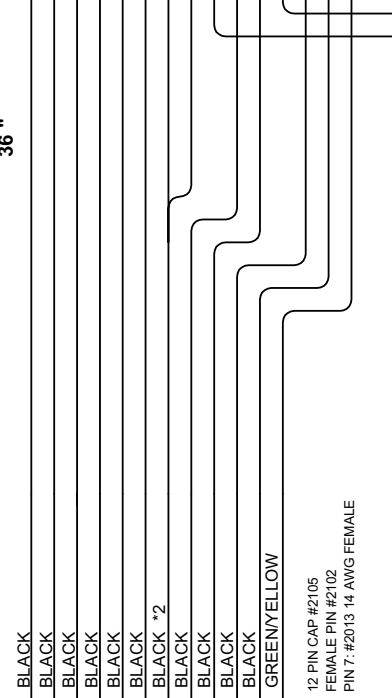

To Main To Rotary Harness

- 1
- 2
- 3
- 4
- 5
- 6
- 7
- 8
- 9
- 10
- 11
- 12

- BLACK
- BLACK
- BLACK
- BLACK
- BLACK
- BLACK *2
- BLACK
- BLACK
- BLACK
- BLACK
- BLACK
- GREEN/YELLOW
- 12 PIN CAP #2105
- FEMALE PIN #2102
- PIN 7: #2013 14 AWG FEMALE

To Door Interconnect Harness

- 1
- 2

- ORANGE/BLACK
- BLACK/WHITE
- 2 PIN PLUG #2103
- SOLID PIN #2100S

TWISTED 36"

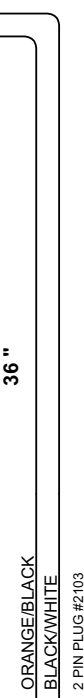

TITLE	ROUND CRANE		
DESCRIPTION	#RC2552AX - ROTARY HARNESS (YELLOW SUB)	FILENAME	RC.VSD
DATE	7/9/01	DRAWN BY	MMARTIN
	REVISED	3/15/02	PAGE 15 OF 21

1 2 3 4

D C B A

1 2 3 4

D C B A

D C B A

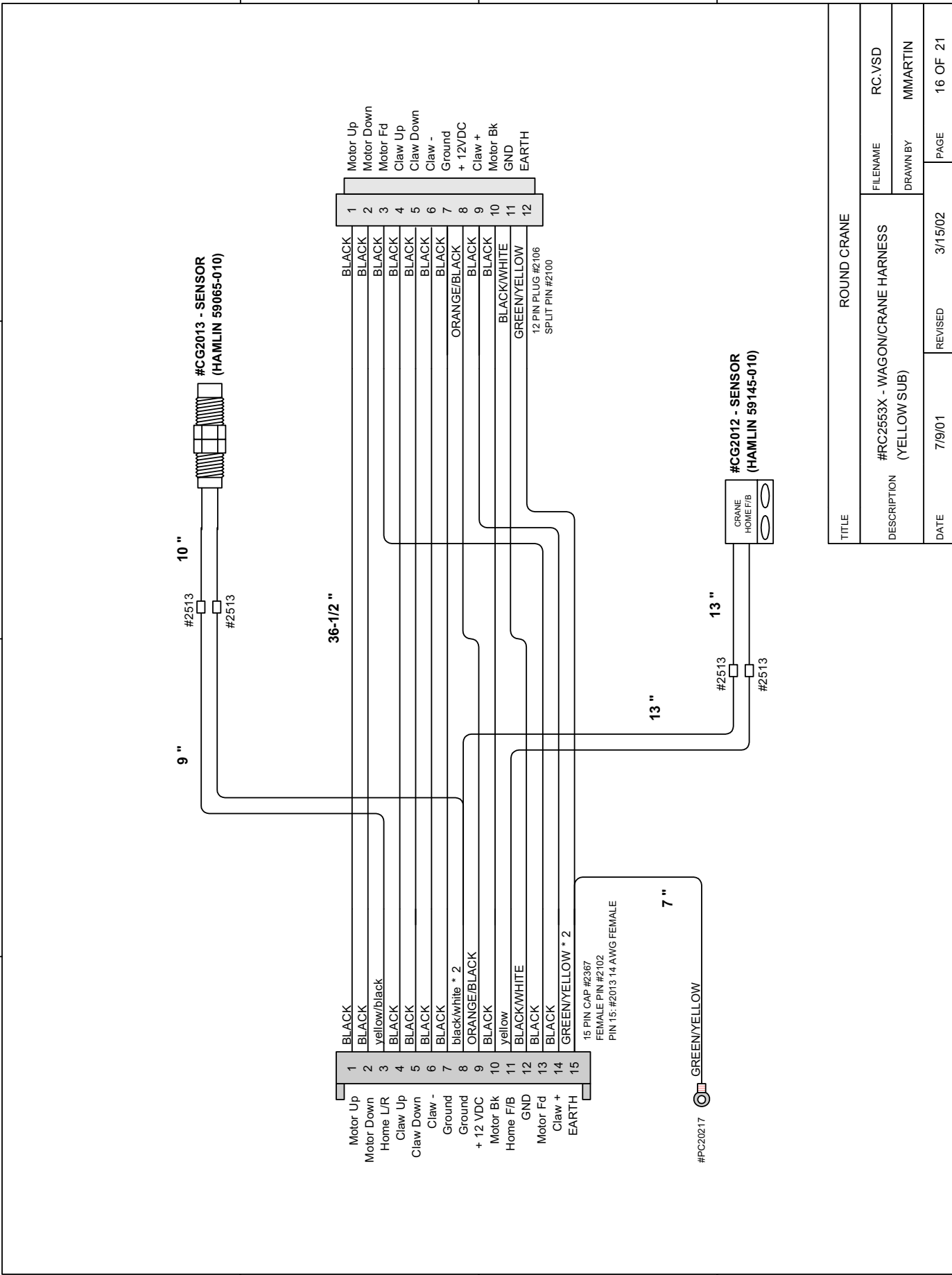

TITLE		ROUND CRANE	
DESCRIPTION	#RC2553X - WAGON/Crane HARNESS (YELLOW SUB)	FILENAME	RC.VSD
DATE	7/9/01	DRAWN BY	MMARTIN
	REVISED	PAGE	16 OF 21

1 2 3 4

1
2
3
4

D C B A

D C B A

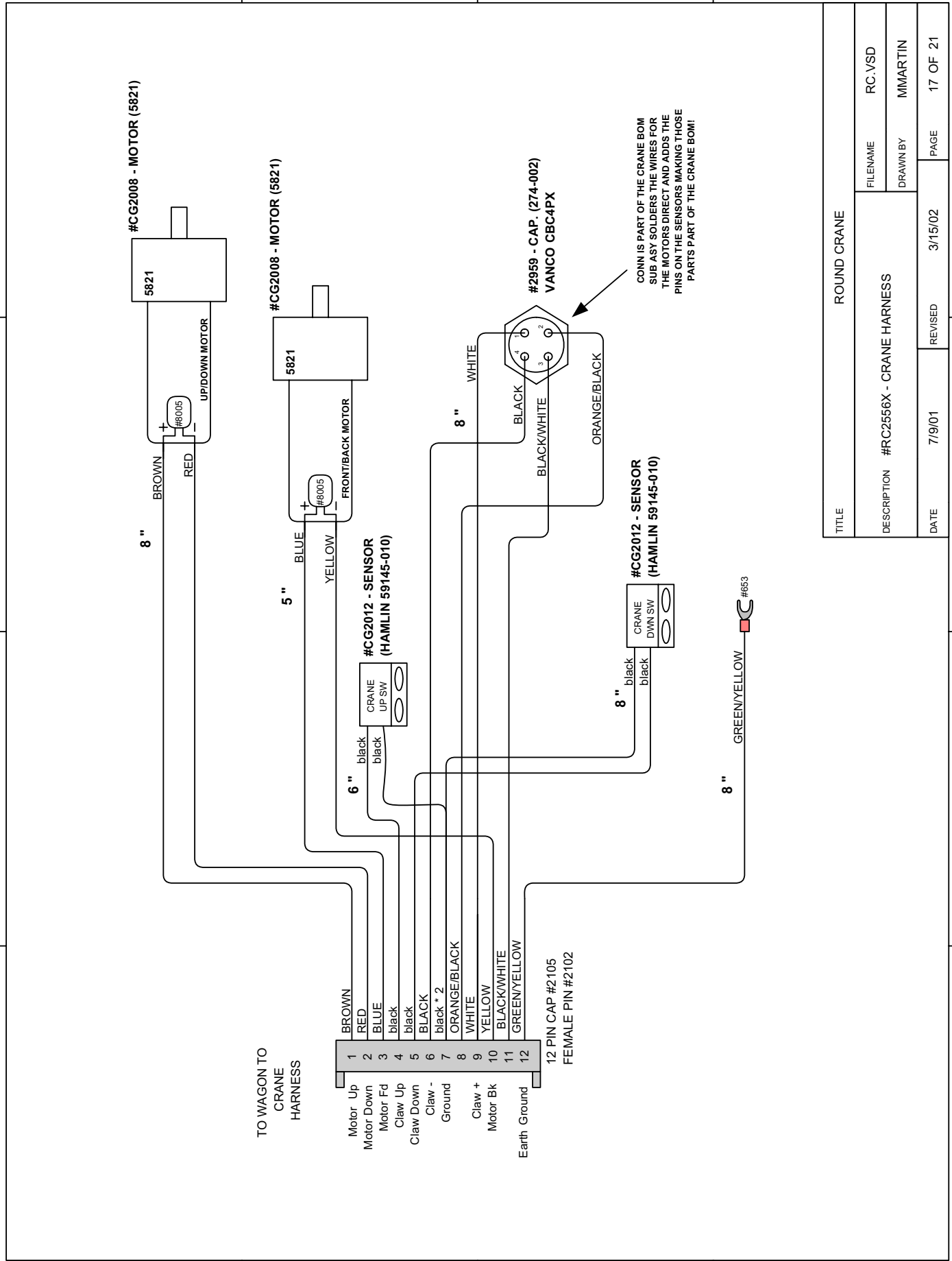

TITLE		ROUND CRANE	
DESCRIPTION	#RC2556X - CRANE HARNESS	FILENAME	RC.VSD
DATE	7/9/01	DRAWN BY	MMARTIN
		REVISED	3/15/02
		PAGE	17 OF 21

1
2
3
4

4 3 2 1

* NOTE: ADD 3" OF 1/8" BLACK SHRINK TUBE #8381

4"

To Solenoid Assembly

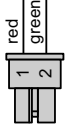

#8497 - 2 PIN MOLEX
MICRO-FIT RECEPTACLE
#8496 - MOLEX MICRO-
FIT FEMALE TERMINAL

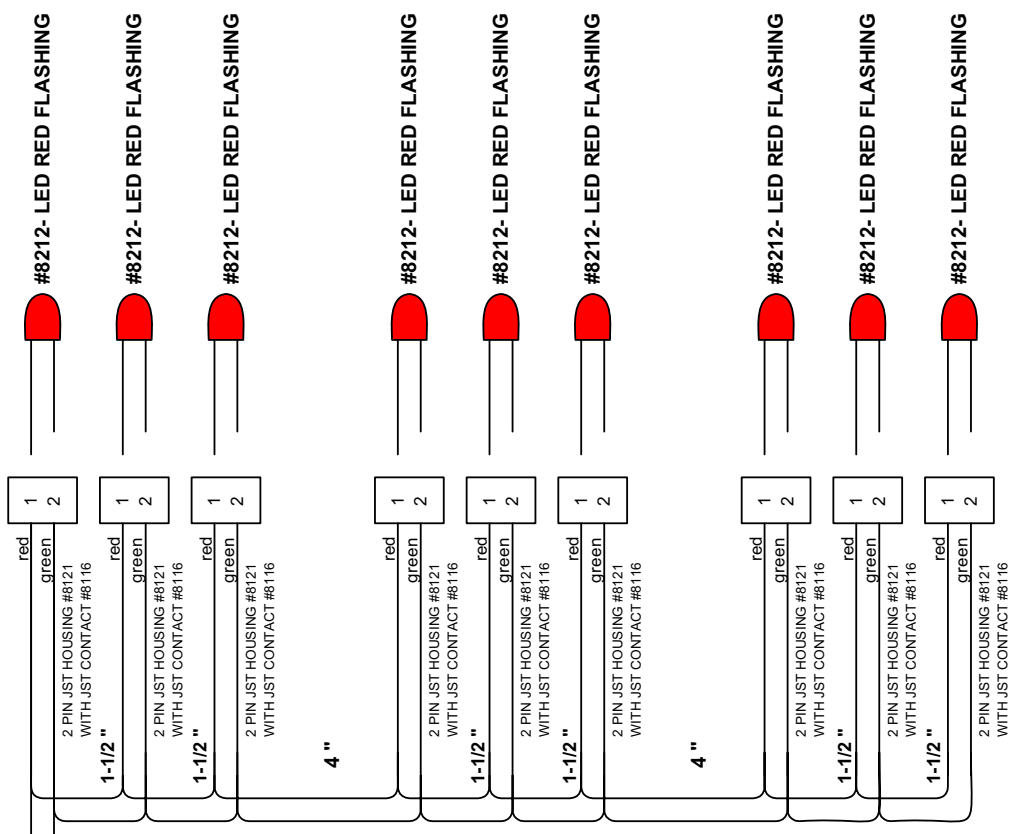

D C B A

4 3 2 1

TITLE		ROUND CRANE	
DESCRIPTION		FILENAME	RC.VSD
DATE		DRAWN BY	MMARTIN
7/9/01	REVISED	3/15/02	PAGE
		18 OF 21	

1
2
3
4

D
C
B
A

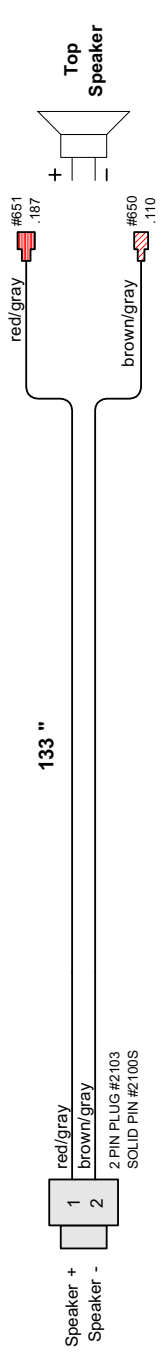

TITLE	ROUND CRANE		
DESCRIPTION	#RC2561X - SPEAKER EXTENSION HARNESS	FILENAME	RC-VSD
DATE	7/9/01	DRAWN BY	MMARTIN
		REVISED	3/15/02
		PAGE	19 OF 21

1
2
3
4

1 2 3 4

D C B A



147"

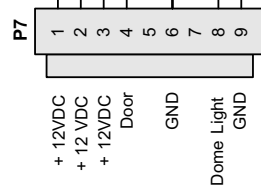

9 PIN PLUG #2282
SPLIT PIN #2100
PIN 6: 20-14 AWG MALE #6260



48"

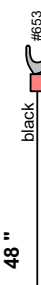

48"

#8489 - SWITCH WIDE GAP

#2111 - RELAY SOLID STATE

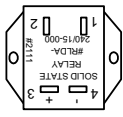

158"

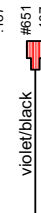
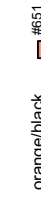

22-1/2" (Full Length)

162"

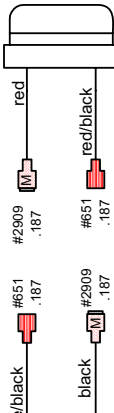

#RC2535X - AMBER STROBE LIGHT ASY.

TITLE		ROUND CRANE	
DESCRIPTION		FILENAME	RC.VSD
DATE		DRAWN BY	MMARTIN
7/9/01	REVISED	3/15/02	PAGE 20 OF 21

1 2 3 4

1 2 3 4

D C B A

#2960 - PLUG (274-001)
VANCO CBC4MX

WRAP END OF CORD JACKET WITH 1" OF
#8069 - SPIRAL WRAP 1/4" BLACK, WHERE
PLUG CLAMPS THE CORD

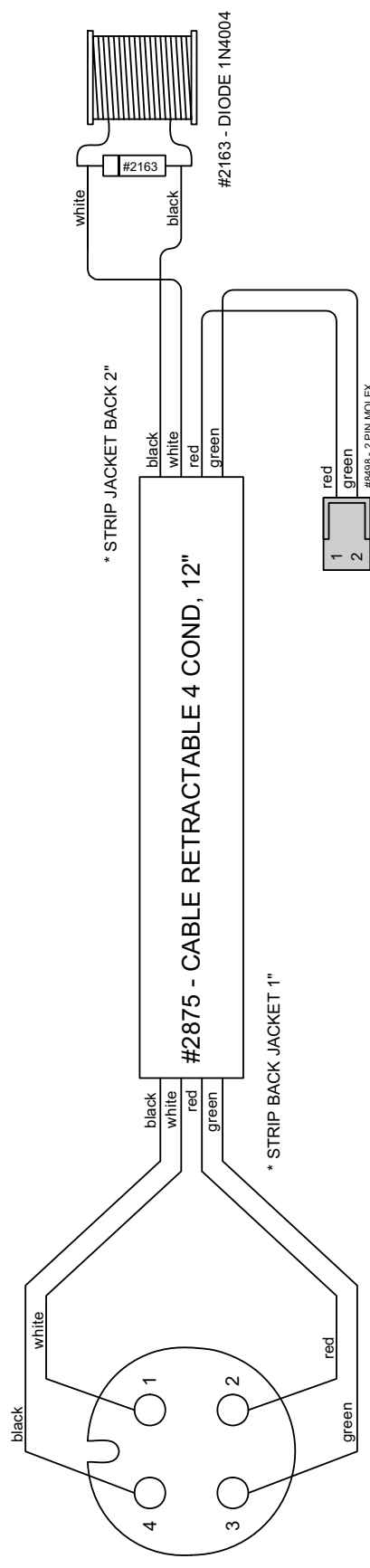

* STRIP JACKET BACK 2"

* STRIP BACK JACKET 1"

FOLD BACK RED AND GREEN WIRES AND
PLACE 1" OF #2611 - SHRINK TUBE FIT 221-
1/4" OVER END OF CORD JACKET

TITLE		ROUND CRANE	
DESCRIPTION	#RC3538X - SOLENOID ASSEMBLY	FILENAME	RC.VSD
DATE	7/9/01	DRAWN BY	MMARTIN
		REVISED	3/15/02
		PAGE	21 OF 21

1 2 3 4

Warranty

I.C.E warrants all components in the **ROUND CRANE** game to be free of defects in materials and workmanship for a period of ninety days from the date of purchase.

This warranty does not cover items damaged due to normal wear and tear, subjected to abuse, improperly assembled by the end user, modified, repaired, or operated in a fashion other than that described in the service manual.

If your **ROUND CRANE** game fails to conform to the above-mentioned warranty, I.C.E.'s sole responsibility shall be at its discretion to repair or replace any defective component with a new or remanufactured component of equal to or greater O.E.M. specification.

I.C.E. will assume no liability whatsoever, for costs associated with labor to replace defective parts, or travel time associated therein.

I.C.E.'s obligation will be to ship free of charge, replacement parts by U.P.S. Ground, U.S. mail, or other comparable shipping means. Any express mail or overnight shipping expense is at the cost of the purchaser.

Products will be covered under warranty only when:

- The serial number of the game with the defective parts is given.
- The serial number of the defective part, if applicable, is given.
- Defective parts are returned to I.C.E., shipping pre-paid, in a timely fashion, if requested by I.C.E.
- A copy of the sales receipt is available as proof of purchase upon request of I.C.E.

I.C.E. distributors are independent, privately owned and operated. In their judgment, they may sell parts or accessories other than those manufactured by I.C.E. We cannot be responsible for the quality, suitability, or safety of any non-I.C.E. part, or any modification, including labor, which is performed by such a distributor.



WARRANTY

ICE Inc warrants that all of its products will be free from defects in material and workmanship.

When placing a warranty request, please be prepared to provide the following information:

- Serial Number of Game or Bill of Sale
- Machine Type
- A Detailed Description of the Equipment Fault Symptoms

ICE product, including Cromptons, Sam's Billiards, Uniana and Bell Fruit is warranted as follows:

- 180 days on the Main PCB and Computers
- 90 days on all other components (i.e. DBV's, Ticket Dispensers, etc)
- 30 days on repaired items
- 3 years on all Crane Harnessing
- 9 Months on Printers

DKS cashless systems offer a 3-year warranty on all components.

ICE Inc shall not be obligated to furnish a warranty request under the following conditions:

- Equipment has been subjected to unwarranted stress through abuse or neglect
- Equipment has been damaged as a result of arbitrary repair/modification attempts
- Equipment that has failed through normal wear and tear

ICE Inc will assume no liability whatsoever for costs associated with labor to replace defective parts or travel time associated therein.

All defective warranty covered components will be replaced with new or factory refurbished components equal to OEM specifications. ICE Inc will cover all UPS ground, or comparable shipping means, freight costs during the warranty period. Expedited shipments are available for an additional charge.

Defective parts are returned to ICE Inc, at the customer's expense, in a timely fashion.

ICE distributors are independent, privately owned and operated. In their judgment, they may sell parts and/or accessories other than those manufactured by ICE Inc. We cannot be responsible for the quality, suitability or safety of any non-ICE part, modification (including labor) that is performed by such a distributor.

I.C.E. Parts/Service Dept.
Innovative Concepts in Entertainment
10123 Main St.
Clarence, NY 14031
Phone #: (716) - 759 - 0360
Fax #: (716) - 759 - 0884