



# **POWER SURGE OWNERS AND SERVICE MANUAL**

**INNOVATIVE CONCEPTS IN ENTERTAINMENT INC.**

**10123 MAIN STREET, CLARENCE, NY 14031**

**SERVICE: 1-716-759-0360**

**FAX: 1-716-759-0884**

**E-MAIL: [service@icegame.com](mailto:service@icegame.com)**

**WEBSITE: [www.icegame.com](http://www.icegame.com)**

# TABLE OF CONTENTS

SAFETY & WARNINGS.....	PAGE 3
• BEFORE YOU BEGIN	
• INSTALLATION	
• WARNING	
GAME SETUP & FEATURES.....	PAGE 4 - 9
• PLAYER CONTROLS	
• PLAYING THE GAME	
• INITIAL GAME SETUP	
TROUBLESHOOTING.....	PAGE 10 –11
DIAGNOSTIC, ADJUSTMENT & AUDIT MENU SYSTEM.....	PAGE 12-22
MAINTENANCE / REPAIR .....	PAGE 23 –32
PARTS LISTING.....	PAGE 33
SCHEMATIC.....	PAGE 34
WARRANTY INFORMATION.....	PAGE 35-36

# SAFETY AND WARNINGS

## BEFORE YOU BEGIN

WARNING: WHEN INSTALLING THIS GAME, A GROUNDED A.C. RECEPTACLE MUST BE USED. FAILURE TO DO SO COULD RESULT IN INJURY TO YOURSELF OR OTHERS. FAILURE TO USE A GROUNDED RECEPTACLE COULD ALSO CAUSE IMPROPER GAME OPERATION, OR DAMAGE TO THE ELECTRONICS.

DO NOT DEFEAT OR REMOVE THE GROUNDING PRONG ON THE POWER CORD FOR THE SAME REASON AS GIVEN ABOVE. USING AN IMPROPERLY GROUNDED GAME COULD VOID YOUR WARRANTY.

HAVE A QUALIFIED ELECTRICIAN CHECK YOUR A.C. RECEPTACLE TO BE SURE THE GROUND IS FUNCTIONING PROPERLY.

## INSTALLATION

The game comes ready to play with just a few simple things to keep in mind.

1. Plug the game into the A.C. outlet and turn on the power switch to the game. The switch for the game is located on a power module on the outside rear of the game.

THIS GAME IS DESIGNED TO DISSIPATE STATIC ELECTRICITY THROUGH THE GROUNDING PLANE OF THE GAME. IF THE A.C. GROUND DOES NOT WORK, THE GAME COULD DISCHARGE STATIC ELECTRICITY THROUGH THE GAME CIRCUITRY, WHICH COULD CAUSE DAMAGE.

2. Make sure the game is level after installation. It is necessary to make sure the game is level for safety concerns.
3. Check that the A.C. voltage rating on the back of the game matches the A.C. voltage of your location.

## WARNING

DO NOT remove any of the components on the main board (e.g. compact flash and eproms) while the game is powered on. This may cause permanent damage to the parts and the main board. Removing any main board component part while powered on will void the warranty.

**NOTE: THIS GAME IS INTENDED FOR INDOOR USE ONLY.  
ON THE BACK PANEL OF THE GAME: WARNING: SHOCK HAZARD - DO NOT OPEN. REFER  
SERVICING TO SERVICE PERSONNEL.**

# INTRODUCTION

## GAME FEATURES

Thank you for your purchase of the new **POWER SURGE™** game from I.C.E.

The brand new **POWER SURGE™** game by I.C.E. was designed with the operator in mind. Reliability, low maintenance, themed cabinetry and semi-metal construction are the key design features, exactly what is needed to ensure a combination of long life and high profit.

With nearly the entire construction made of metal, it was only natural to Powder Epoxy Coat everything, inside and out. This provides the owner-operator with a game that will certainly outlast its wooden counterparts for many years to come. The major advantages of metal construction include:

- Long service life
- Low maintenance
- High durability

All windows of the **POWER SURGE™** game, are 1/4" tempered plate glass to provide an easy to clean, maximum safety, scratch resistant surface.

The first step in I.C.E.'s new merchandiser was to select several leading merchandisers available on the market today, observe and determine what problems can be or are causes of failure and costly down time. I.C.E. then surveyed operators nation wide, requesting information like:

- What are the leading causes of failures in your locations
- What are some problems in servicing merchandisers
- What changes would you make to current merchandisers to create a better machine

I.C.E.'s engineers then compiled all critical data, addressed and corrected each problem and used this information to create what we now call **POWER SURGE™**.

This method of design ensures that the needs of the owner-operators dictate the final design parameters, for who knows a merchandisers attributes and faults better than a merchandiser operator.

## GAME PLAY

The objective is to keep the lower electrode lined up with the top electrode to continuously create the surge of power.



As you keep the electrodes lined up the words "POWER SURGE" energize during the allotted game time. Once P-O-W-E-R is fully lit a mini prize may be vended unless the player chooses to continue in attempting to light S-U-R-G-E and risking it all in order to win a major prize!

## AC MAIN POWER

The main AC power switch is located on the back of the machine at the bottom. To turn the machine on, toggle the switch so the I is pushed in. To turn off, toggle the switch down so the 0 is pushed in.



# GAME SETUP AND FEATURES

## ADJUSTING POWER

Before putting the game in service, it may be necessary to adjust the DC voltage outputs from both the main power supply and secondary supply. Both supplies are accessed from behind the game so start by removing the back and follow the directions below.

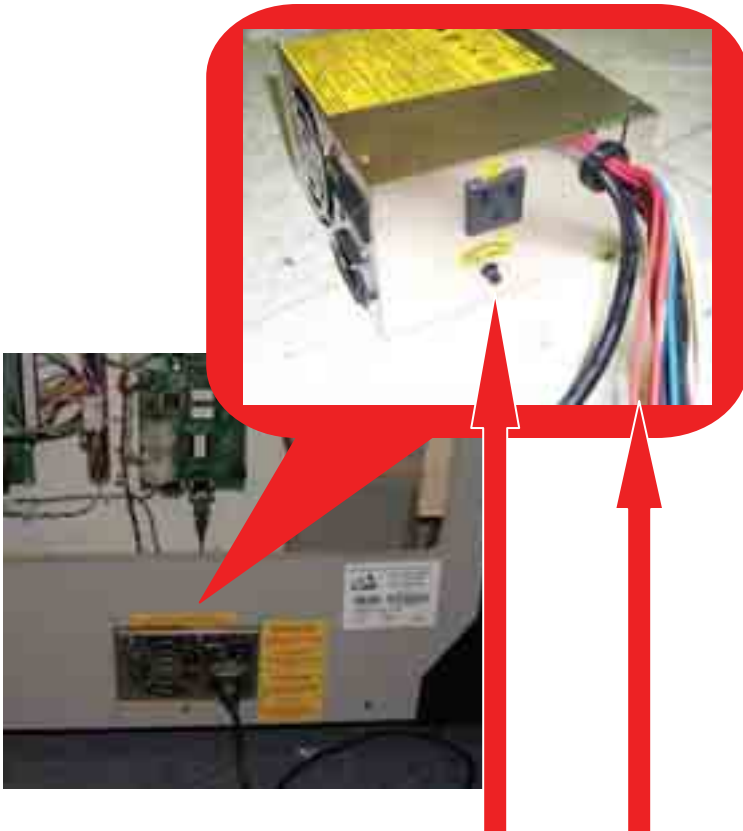

With the power on the game, check the output voltage from either of the connectors from the power supply. The specification is 4.95—5.05 volts DC. Use the RED and BLACK wires to check voltage.



This power supply should be adjusted by measuring with your volt meter. Use the red wire from your volt meter to connect +12 and the black wire from your volt meter to GROUND (GND). Turn the adjustment pot until your volt meter reads as close to 12 as possible. The +24 volt will be higher than +24, around +26 which is ok.

**\*\*\* Please note \*\*\***

When replacing this power supply, the load resistor must be installed on the replacement power supply.

# GAME SETUP AND FEATURES

## PRIZE SENSOR ADJUSTMENTS

When you first install your Power Surge or replace the prize sensor you will need to adjust it for your location. This is necessary because if the prize sensor fails or is incorrectly set then the game will go out of order. Follow the steps below to adjust your prize sensor. Failure to do so will result in unreliable operation and lost earnings.

To adjust the prize sensor you must first gain access to it. Remove the four bolts that hold the main harness and boards assembly. Do not unplug any wire harnesses as none will be in the way of adjusting the sensor. Leave the assembly as shown below.

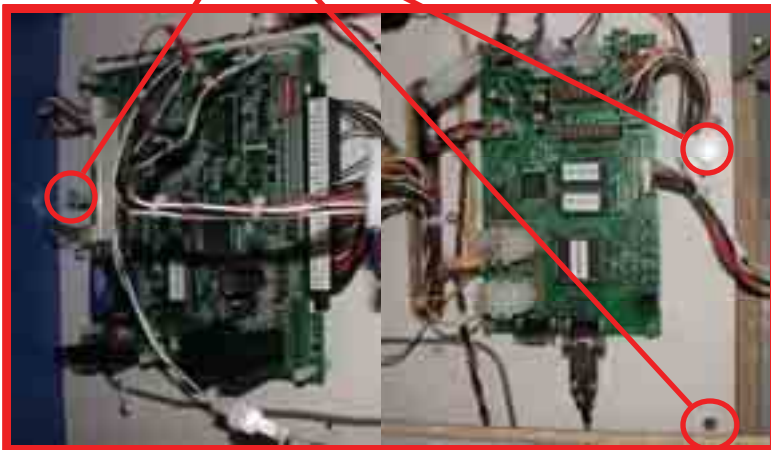

Adjust the prize sensor by first turning the pot until the LED lights red. Then turn the pot the opposite direction until the LED just turns off. The prize sensor is now set for optimal operation.

# GAME SETUP AND FEATURES

## LOADING PRODUCT

Before you can begin to load prizes you must first know the largest size of the prizes. Set the motor timeout to how many turns it would take to allow the largest prize to fall. When the prize falls it will trigger the prize sensor and turn off the motor. If the prize sensor fails then the game will shut down and go out of order and not dispense any prizes. To load the prizes remove the center bar. Unscrew the center bar counter-clockwise. Attach the prize by the loop depending on the size of the prize. If the prize will fit every loop then you can load it every loop if desired. When a dispenser runs out of product the game will turn that dispenser off and allow the customer to select a different dispenser. You must reset this in programming once you have reloaded the prizes on the dispenser.

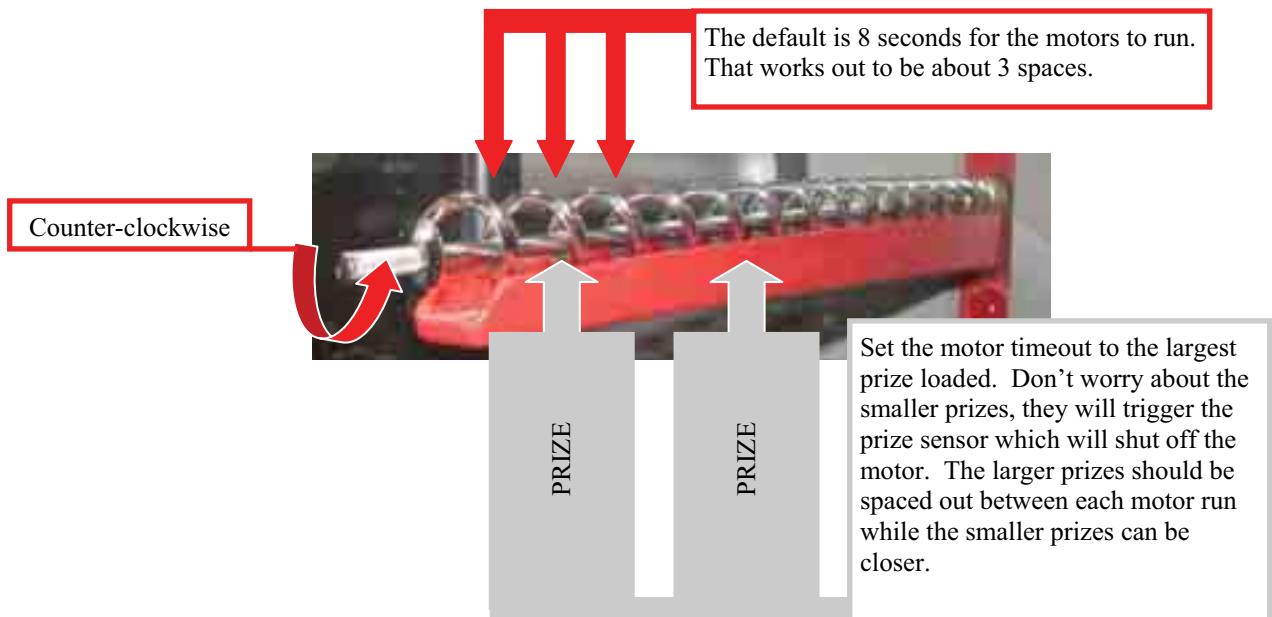

# GAME SETUP AND FEATURES

## TESTING

After the initial setup, it is time to test your game for proper operation.

1. Locate the game in its permanent location and lock the casters.
2. Be sure that the game has been properly plugged into a three prong grounded outlet and that the receptacle is in good working order.
3. If using an extension cord, be sure it is a three prong grounded type of at least 16 Ga.
4. Turn the power to the game on.
5. The game will run through a test mode at every start up. See test mode explanation in the programming section for details.
6. Insert coins/bills at least ten times into the coin mech/bill acceptor to assure proper operation.
7. Check the credit and prize counters for proper operation.
9. Check game volume during busy time at location to set it at the proper level.
10. Play at one game to ensure other controls are functioning.

## CLEANING

Regular cleaning of the game will keep it looking new and greatly enhance its appeal.

Clean the windows of your **POWER SURGE™** with a standard window cleaner such as Windex®

Clean the cabinet sides with a good cleaner such as “Fantastik” or “409” and a soft rag. A mild soapy solution can also be used.

**NOTE: DO NOT USE ALCOHOL, THINNERS OF ANY KIND OR PINBALL PLAYFIELD CLEANERS ON ANY OF THE CABINET SURFACES, ESPECIALLY THE DECALS.**

**IF YOU HAVE ANY QUESTIONS OR COMMENTS REGARDING INSTALLATION OR PROPER FUNCTION OF YOUR GAME, PLEASE CALL OUR SERVICE DEPARTMENT AT 1-716-759-0360**

# GAME SETUP AND FEATURES

## Game Setup Location

The sizes shown on the diagram below will help you determine the area required for your game, and where you might want the game to be placed.

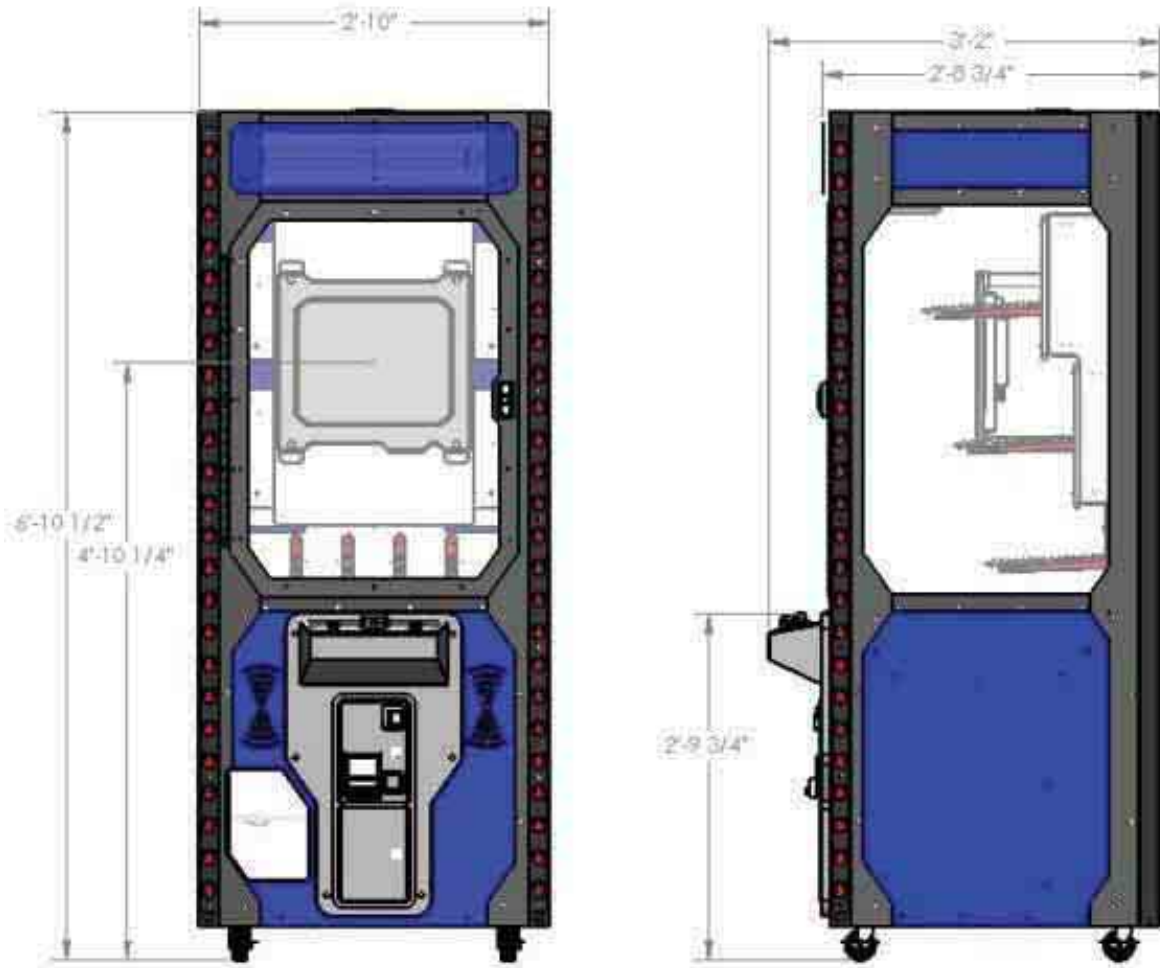

# QUICK TROUBLESHOOTING

PROBLEM	PROBABLE CAUSE	SOLUTION
NO GAME POWER	ON-OFF SWITCH ON THE GAME IS TURNED OFF BAD FUSE AT POWER MODULE GAME UNPLUGGED TRIPPED CIRCUIT BREAKER DAMAGED POWER CORD	TURN POWER ON INSPECT MAIN FUSES CHECK POWER CORD REPLACE CORD
GAME WILL NOT TAKE COINS / TOKENS	NO COIN / TOKEN IN COIN MECH BAD HARNESSING OR CONNECTOR BAD MAIN P.C. BOARD	INSERT COIN / TOKEN BEING USED CHECK AND REPAIR REPAIR OR REPLACE
GAME HAS NO SOUND	BAD SPEAKER VOLUME LEVEL SET INCORRECTLY  BAD HARNESSING OR CONNECTOR BAD MAIN P.C. BOARD	REPLACE SPEAKER(S) CHECK SERVICE MANUAL FOR VOLUME SETTING PROCEDURES CHECK AND REPAIR CHECK, REPAIR OR REPLACE AS NECESSARY.
TICKET DISPENSER DOES NOT WORK OR WORKS IMPROPERLY	BAD HARNESSING BAD TICKET DISPENSER DISPENSER OUT OF TICKETS BAD MAIN P.C. BOARD  OPTICAL SENSOR ON DISPENSER DIRTY	CHECK AND REPAIR REPAIR OR REPLACE ADD TICKETS CHECK, REPAIR OR REPLACE AS NECESSARY CLEAN SENSOR
GAME LOSES SOUND DURING GAME PLAY	STATIC ELECTRICITY	RESET POWER TO GAME
DISPLAYS DO NOT WORK	BAD 12V FUSE BASE DISPLAY P.C. BOARD BAD MAIN P.C. BOARD LOOSE OR DAMAGED DISPLAY HARNESSING	REPLACE WITH PROPER FUSE REPAIR OR REPLACE P.C. BOARD REPAIR OR REPLACE P.C. BOARD CHECK W/ METER AND REPAIR

# TROUBLESHOOTING

## CAUTION

This game uses complex electronic components that are very sensitive to static electricity. Observe precautions below before handling these electronics. Failure to do so may void the warranty and damage electronic assemblies.

Before servicing electronics, turn off AC power to the game. Wait for capacitors to discharge. DO NOT remove any of the components on the main board (e.g. compact flash and EPROMS) while the game is powered on. This may cause permanent damage to the parts and the main board.

Before touching or handling electronic assemblies, discharge static electricity on your body. To discharge this static, begin by connecting the line cord to a grounded outlet. Don't turn on the game. Next, touch the safety ground stud of the power supply chassis.

Store electronic assemblies in an anti-static area. Use anti-static bags to store or transport the game circuit boards.

Don't remove or connect electronic assemblies when cabinet power is on. Otherwise, you'll damage electronic assemblies and void the game's warranty.

After you complete maintenance or service, replace ground wires, shields, safety covers and install and tighten ground and mounting screw.

Video game monitors generate and store potentially high voltages. Avoid touching any part of the monitor until power has been off for some time. A picture tube can maintain a hazardous charge for up to several days. Only qualified technicians should service monitors.

## Game Is Non-Functional

1.	Verify that the game power switch is turned on.
2.	Verify that earth ground is properly connected and all exposed metal points are properly grounded.
3.	Verify that the line cord connector is firmly and correctly seated into the power entry module of AC power chassis.
4.	Verify that correct AC line voltage is present at the outlet
5.	Verify that the DC power supply voltages are present on both power supplies.
6.	If game sounds can be heard but no picture is seen on the monitor, see monitor is non functional

## Monitor Is Non-Functional

1.	Verify the cabinet has AC line voltage present at the monitor and has earth ground connected.
2.	Make sure LCD monitor is on.

## Sound Is Non-Functional

1.	Verify the cabinet wiring is correct. Ensure that the speakers are properly connected to the audio wires from the audio amp.
----	--

## Game Controls Are Non-Functional

1.	Verify that the each individual signal wire for each switch is connected.
----	---

# DIAGNOSTIC, ADJUSTMENT AND AUDIT MENU SYSTEM

## Menu System

The game's menu system is a series of on screen menus that allow the operator to setup and adjust the settings. Each menu item leads to another menu, a list of data or provides the ability to modify the adjustment.

## Starting the Menu System

Press the Diagnostics control switch inside the coin door to access the on screen menu system.

## Navigating the Menu

Use the following buttons to navigate the menu system:

Volume Up button to move the cursor up.

Volume Down button to move the cursor down.

Diagnostic button to select.

Once an item has been selected, use the Volume Up/Volume Down button to change the settings. Once an item has been changed, press the Diagnostic button to save the desired setting.

## Main Menu

All system tests, audits and game adjustments are accessible from the MAIN MENU.

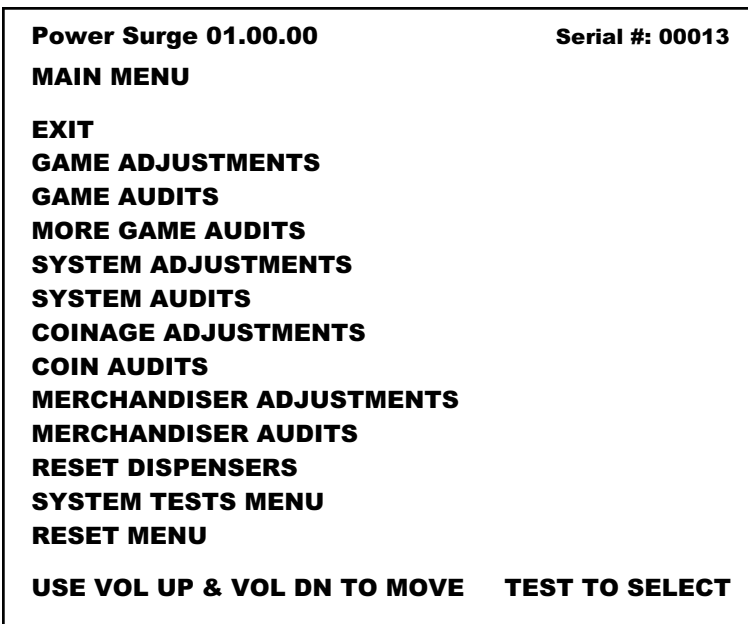

# DIAGNOSTIC, ADJUSTMENT AND AUDIT MENU SYSTEM

<b>Power Surge 01.00.00</b>	<b>Serial #: 00013</b>
<b>GAME ADJUSTMENTS</b>	
<b>MAIN MENU</b>	
<b>GAME TIME</b>	<b>15</b>
<b>BONUS TIME</b>	<b>10</b>
<b>INPUT SENSITIVITY</b>	<b>0</b>
<b>PRIZES IN FREE PLAY</b>	<b>ON</b>
<b>POWER PRIZE AUTO PERCENT</b>	<b>ON</b>
<b>PLAY VALUE</b>	<b>\$1.00</b>
<b>PRIZE PAYOUT</b>	<b>35%</b>
<b>POWER PRIZE COST</b>	<b>\$100.00</b>
<b>MINI-PRIZE DIFFICULTY</b>	<b>2-1:2</b>
<b>MINI PRIZE AUTO PERCENT</b>	<b>ON</b>
<b>MINI-PRIZE COST</b>	<b>\$1.00</b>
<b>POWER PRIZE DIFFICULTY</b>	<b>5-1:60</b>
<b>USE VOL UP &amp; VOL DN TO MOVE TEST TO SELECT</b>	

## **Game Time** - (min=1, max=60, default=15)

The amount of time (in seconds) that a player has to complete "POWER" for a Mini-Prize.

## **Bonus Time** - (min=1, max=60, default=10)

Amount of additional time (in seconds) that a player has to complete "SURGE" for a Power Prize. This amount is added to the remaining Game Time if a player chooses to go for a Power Prize after achieving the Mini-Prize.

## **Input Sensitivity** - (min=0, max=10, default=0)

How far the electrode will move on screen in relation to how far knob is turned.

## **Prizes in Free Play** - (ON / OFF, default=ON)

Set whether or not you want the game to dispense prizes while in Free Play.

## **Power Prize Auto Percent** - (ON / OFF, default=OFF)

Allows operator to set cost per play, value of Power Prize and Percentage of payout which the game will follow. If the option is set to OFF, the game will follow the "Power Prize Difficulty" settings (see below).

## **Mini Prize Auto Percent** - (ON / OFF, default=OFF)

Allows operator to set cost per play, value of Mini Prize and Percentage of payout which the game will follow. If the option is set to OFF, the game will follow the "Mini Prize Difficulty" settings (see below).

*If Power Prize Auto Percent is OFF, the following will display:*

## **Power Prize Difficulty** - (min=1, max=10, default=5)

Set the ratio of how many times the game will pay out a Power Prize as compared to how many times the game is played (i.e. 5-1:600 means settings 5 pays out one Power Prize per every (approximately) 600 plays. This setting is only available if "Power Prize Auto Percent" is set to OFF. Otherwise, the game will follow the "Power Prize Auto Percent" settings.

Options 1=1:100, 2=1:200, 3=1:400, 5=1:600, 6=1:700, 7=1:800, 8=1:900, 9=1:1000, 10=1:1200

*If Power Prize Auto Percent is ON, the following will display:*

## **Play Value** - (min=\$0.01, max=\$5.00, default=\$1.00)

Set the amount that each play is worth (i.e. If coin slots #1 & 2 accept quarters and in Coinage Adjustments each slot is set to 1 unit per coin and "Coins to Start" is set to 4, the Play Value would be \$1.00 (4x\$0.25). This option is part of the "Power Prize Auto Percent" and "Mini Prize Auto Percent" settings, and is only visible if one of the Auto Percent features is set to ON.

- continued on next page -

# DIAGNOSTIC, ADJUSTMENT AND AUDIT MENU SYSTEM

## **Prize Payout** - (min=1%, max=100%, default=35%)

Percentage of money the operator would like to pay out (via prizes) compared to money put in the game. The game uses the "Play Value" option along with "Power Prize Cost" and/or "Mini Prize Cost" to pay out this percentage. (This option is part of the "Power Prize Auto Percent" and "Mini Prize Auto Percent" settings, and is only visible if one of the Auto Percent features is set to ON).

## **Power Prize Cost** - (min=\$1.00,max=\$1,000.00, default=\$100.00)

This is the average value of Power Prizes in the game. It is used to calculate the "Prize Payout" percentage. (This option is only available if "Power Prize Auto Percent" is turned ON).

*If Mini-Prize Auto Percent is OFF, the following will display:*

## **Mini Prize Difficulty** - (min=1, max=10, default=2)

Set the ratio of how many times the game will pay out a Power Prize as compared to how many times the game is played. (i.e. 5 - 1:600 means settings 5 pays out one Power Prize per every (approximately) 600 plays). This setting is only available if "power Prize Auto Percent" is set to OFF. Otherwise, the game will follow the "Power Prize Auto Percent" settings.

Options: 1=1:1, 2=1:2, 3=1:4, 4=1:10, 5=1:15, 6=1:20, 7=1:25, 8=1:30, 9=1:40, 10=1:50

*If Mini Prize Auto Percent is ON, the following will display:*

## **Mini Prize Cost** - (min=\$1.00,max=\$1,000.00, default=\$1.00)

This is the average value of Mini Prizes in the game. It is used to calculate the "Prize Payout" percentage. (This option is only available if "Mini Prize Auto Percent" is turned on).

# DIAGNOSTIC, ADJUSTMENT AND AUDIT MENU SYSTEM

<b>Power Surge 01.00.00</b>	<b>Serial #: 00013</b>
<b>GAME AUDITS</b>	
<b>MAIN MENU</b>	
<b>PLAYER STARTS</b>	<b>0</b>
<b>PLAYER CONTINUES</b>	<b>0</b>
<b>PLAYTIME</b>	<b>0Y 0D 00:00:00</b>
<b>TIME NOT CONNECTED</b>	<b>0Y 0D 00:00:00</b>
<b>HELP GRAPHICS SHOWN</b>	<b>0</b>
<b>USE VOL UP &amp; VOL DN TO MOVE    TEST TO SELECT</b>	

**Player Starts** – How many credits were used to start new games.

**Player Continues** – How many credits were used to continue games.

**Playtime** – Cumulative amount of time the game has been played.

**Time not connected** – Total amount of playtime where the two electrodes were not connected.

**Help Graphics Shown** – Amount of time the game displayed “Stay Connected-Turn Knob” (this will display when the player has not created a connection between the electrodes for 3 seconds).

# DIAGNOSTIC, ADJUSTMENT AND AUDIT MENU SYSTEM

<b>Power Surge 01.00.00</b>	<b>Serial #: 00013</b>
<b>MORE GAME AUDITS</b>	
<b>MAIN MENU</b>	
<b>GAME ENDED IN POWER 'P'</b>	<b>0</b>
<b>GAME ENDED IN POWER 'O'</b>	<b>0</b>
<b>GAME ENDED IN POWER 'W'</b>	<b>0</b>
<b>GAME ENDED IN POWER 'E'</b>	<b>0</b>
<b>GAME ENDED IN POWER 'R'</b>	<b>0</b>
<b>ACHIEVED MINI-PRIZE</b>	<b>0</b>
<b>GAME ENDED IN SURGE 'S'</b>	<b>0</b>
<b>GAME ENDED IN SURGE 'U'</b>	<b>0</b>
<b>GAME ENDED IN SURGE 'R'</b>	<b>0</b>
<b>GAME ENDED IN SURGE 'G'</b>	<b>0</b>
<b>GAME ENDED IN SURGE 'E'</b>	<b>0</b>
<b>ACHIEVED POWER PRIZE</b>	<b>0</b>
<b>USE VOL UP &amp; VOL DN TO MOVE    TEST TO SELECT</b>	

**Game ended in POWER 'P'** - How many games ended while player was attempting to fill the letter "P".

**Game ended in POWER 'O'** - How many games ended while player was attempting to fill the letter "O".

**Game ended in POWER 'W'** - How many games ended while player was attempting to fill the letter "W".

**Game ended in POWER 'E'** - How many games ended while player was attempting to fill the letter "E".

**Game ended in POWER 'R'** - How many games ended while player was attempting to fill the letter "R".

**Achieved Mini-Prize** - How many times the players were able to complete the word "POWER", making them eligible for a Mini-Prize..

**Game ended in SURGE 'S'** - How many games ended while player was attempting to fill the letter "S".

**Game ended in SURGE 'U'** - How many games ended while player was attempting to fill the letter "U".

**Game ended in SURGE 'R'** - How many games ended while player was attempting to fill the letter "R".

**Game ended in SURGE 'G'** - How many games ended while player was attempting to fill the letter "G".

**Game ended in SURGE 'E'** - How many games ended while player was attempting to fill the letter "E".

**Achieved Power Prize** - How many times the players were able to complete both the words "POWER" and "SURGE", and won a Power Prize.

<b>Power Surge 01.00.00</b>	<b>Serial #: 00013</b>
<b>SYSTEM ADJUSTMENTS</b>	
<b>MAIN MENU</b>	
<b>MINIMUM VOLUME</b>	<b>0</b>
<b>ATTRACT SOUND</b>	<b>ON</b>
<b>WATCHDOG</b>	<b>ON</b>
<b>USE VOL UP &amp; VOL DN TO MOVE    TEST TO SELECT</b>	

**Minimum Volume** - (min=0, max=255, default=90)  
The minimum value that the volume can be lowered to by pressing the Vol Down button while the game is in attract mode or game mode.

**Attract Sound** - (ON/OFF/OCCASIONALLY, default=ON)

**Watchdog** - (ON / OFF, default=ON)  
Turns the watchdog timer ON or OFF. The watchdog timer will reset the game in case the game hangs, keeping the game operational. It is recommended this be left ON.

# DIAGNOSTIC, ADJUSTMENT AND AUDIT MENU SYSTEM

<b>Power Surge 01.00.00</b>	<b>Serial #: 00013</b>
<b>SYSTEM AUDITS</b>	
<b>MAIN MENU</b>	
<b>UP TIME</b>	<b>0Y 0D 00:00:00</b>
<b>PLAY TIME</b>	<b>0Y 0D 00:00:00</b>
<b>PLAYER STARTS</b>	<b>1</b>
<b>PLAYER CONTINUES</b>	<b>0</b>
<b>USE VOL UP &amp; VOL DN TO MOVE    TEST TO SELECT</b>	

**Up Time** – Total amount of time game has been powered on.  
**Play Time** – Cumulative amount of time the game has been played.  
**Player Starts** – Total number of times credits were used to start a game.  
**Player Continues** – Total number of times credits were used to continue playing.

<b>Power Surge 01.00.00</b>	<b>Serial #: 00013</b>
<b>COINAGE ADJUSTMENTS</b>	
<b>MAIN MENU</b>	
<b>COIN SLOT 1 UNITS</b>	<b>1</b>
<b>COIN SLOT 2 UNITS</b>	<b>1</b>
<b>COINS TO START</b>	<b>4</b>
<b>MAXIMUM CREDITS</b>	<b>50</b>
<b>FREE PLAY</b>	<b>OFF</b>
<b>USE VOL UP &amp; VOL DN TO MOVE    TEST TO SELECT</b>	

**Coin Slot 1 Units** - (min=OFF, max=20, default=1)  
 Sets the amount of units given per coin inserted to Coin Slot 1 (you can also turn the coin slot OFF to disable it).  
**Coin Slot 2 Units** - (min=OFF, max=20, default=1)  
 Sets the amount of units given per coin inserted to Coin Slot 2 (you can also turn the coin slot OFF to disable it).  
**Coins to Start**- (min=1, max=10, default=4)  
 Sets the total amount of credits (units) required to start a game.  
**Maximum Credits** - (min=OFF, max=99, default=50)  
 Set the maximum amount of credits the game will hold.  
**Free Play** - (OFF / ON, default=OFF)  
 Turns Free Play ON or OFF.

# DIAGNOSTIC, ADJUSTMENT AND AUDIT MENU SYSTEM

**Power Surge 01.00.00** **Serial #: 00013**

**COINAGE AUDITS**

**MAIN MENU**

<b>COIN 1</b>	<b>3</b>
<b>COIN 2</b>	<b>2</b>
<b>PAID CREDITS</b>	<b>5</b>
<b>LIFETIME COIN COUNT</b>	<b>5</b>

**USE VOL UP & VOL DN TO MOVE    TEST TO SELECT**

**Coin 1** – Total number of coins inserted in Coin Slot 1.

**Coin 2** – Total number of coins inserted in Coin Slot 2.

**Paid Credits** – Total number of credits given by coins inserted in all coin slots.

**Lifetime Coin Count** – Total number of coins inserted in all coin slots.

**Power Surge 01.00.00** **Serial #: 00013**

**MERCHANDISER ADJUSTMENTS**

**MAIN MENU**

<b>DISPENSE TIME</b>	<b>8</b>
<b>PRIZE SENSOR AUTO TEST</b>	<b>YES</b>
<b>DISPENSER 1</b>	<b>ON</b>
<b>DISPENSER 2</b>	<b>ON</b>
<b>DISPENSER 3</b>	<b>ON</b>
<b>DISPENSER 4</b>	<b>ON</b>
<b>DISPENSER 5</b>	<b>ON</b>
<b>DISPENSER 6</b>	<b>ON</b>
<b>DISPENSER 7</b>	<b>ON</b>
<b>DISPENSER 8</b>	<b>ON</b>
<b>DISPENSER 9</b>	<b>ON</b>
<b>DISPENSER 10</b>	<b>ON</b>

**USE VOL UP & VOL DN TO MOVE    TEST TO SELECT**

**Dispense Time** - (min=1, max=30, default=8)

**Prize Sensor Auto Test** - (YES / NO, default=YES)

**Dispenser 1** - (OFF / ON, default=ON)

**Dispenser 2** - (OFF / ON, default=ON)

**Dispenser 3** - (OFF / ON, default=ON)

**Dispenser 4** - (OFF / ON, default=ON)

**Dispenser 5** - (OFF / ON, default=ON)

**Dispenser 6** - (OFF / ON, default=ON)

**Dispenser 7** - (OFF / ON, default=ON)

**Dispenser 8** - (OFF / ON, default=ON)

**Dispenser 9** - (OFF / ON, default=ON)

**Dispenser 10** - (OFF / ON, default=ON)

# DIAGNOSTIC, ADJUSTMENT AND AUDIT MENU SYSTEM

<b>Power Surge 01.00.00</b>		<b>Serial #: 00013</b>
<b>MERCHANDISER AUDITS</b>		
<b>MAIN MENU</b>		
<b>TOTAL PRIZES DISPENSED</b>	<b>0</b>	
<b>MINI-PRIZES SELECTED</b>	<b>0</b>	
<b>MINI-PRIZES DISPENSED</b>	<b>0</b>	
<b>POWER PRIZES SELECTED</b>	<b>0</b>	
<b>POWER PRIZES DISPENSED</b>	<b>0</b>	
<b>PAYOUT GAMES</b>	<b>0</b>	
<b>MONEY PLAYED</b>	<b>\$0.00</b>	
<b>MONEY OUT</b>	<b>\$0.00</b>	
<b>PRIZE SENSOR TRIGGERED</b>	<b>0</b>	
<b>USE VOL UP &amp; VOL DN TO MOVE</b>		<b>TEST TO SELECT</b>

- Total Prizes Dispensed** – Total number of prizes dispensed.
- Mini-Prizes Selected** – Total number of Mini-Prizes a player has won and selected to dispense.
- Mini-Prizes Dispensed** – Total number of Mini-Prizes that fell through the prize sensor and the game counted as “dispensed”.
- Power Prizes Selected** – Total number of Power Prizes a player has won and selected to dispense.
- Power Prizes Dispensed** – Total number of Power Prizes that fell through the prize sensor and the game counted as “dispensed”.
- Payout Games** – Total number of games that resulted in a Prize Payout (both Mini-Prize and Power Prize combined).
- Money Played** – Total amount of money that has been used to start and continue games.
- Money Out** – Total amount of money paid out in prizes (based on “Power Prize Cost” and “Mini Prize Cost” amounts).
- Prize Sensor Triggered** – Total number of times the Prize Sensor has sensed something pass through it.

<b>Power Surge 01.00.00</b>		<b>Serial #: 00013</b>
<b>SCREEN TESTS MENU</b>		
<b>MAIN MENU</b>		
<b>SWITCH INPUT TEST</b>		
<b>VIDEO SCREEN TEST</b>		
<b>SOUND TESTS</b>		
<b>MERCHANDISER TEST</b>		
<b>PRIZE SENSOR TEST</b>		

- Switch Input Test** - Use this to test the switches on the game.
- Video Screen Test** - Use this to test and adjust the image on the LCD monitor.
- Sound Tests** - Use this to test game sounds and audio.
- Merchandiser Test** - Use this to test the mechanisms that dispense prizes.
- Prize Sensor Test** - Make sure nothing is blocking the sensor. Test will run continuously every 5 seconds. Press any button to continue.

# DIAGNOSTIC, ADJUSTMENT AND AUDIT MENU SYSTEM

<b>Power Surge 01.00.00</b>	<b>Serial #: 00013</b>
<b>SWITCH INPUT TEST</b>	
<b>MAIN MENU</b>	
<b>COIN 1</b>	
<b>COIN 2</b>	
<b>START</b>	
<b>VOLUME DOWN</b>	
<b>VOLUME UP</b>	
<b>TEST</b>	
<b>COIN 3</b>	
<b>SELECT</b>	
<b>PRIZE SENSOR</b>	
<b>PRESS VOL UP &amp; DN TO EXIT</b>	

- Coin 1** - Will turn GREEN when Coin Switch #1 is closed.
- Coin 2** - Will turn GREEN when Coin Switch #2 is closed.
- Start** - Will turn GREEN when Start Button is Depressed.
- Volume Down** - Will turn GREEN when Volume Down Button is depressed.
- Volume Up** - Will turn GREEN when Volume Down Button is depressed.
- Test** - Will turn GREEN when Test Button is depressed.
- Coin 3** - Will turn GREEN when Coin Switch #1 is closed.
- Select** - Will turn GREEN when Select Button is depressed.
- Prize Sensor** - Will turn GREEN when Prize Sensor is blocked.

<b>Power Surge 01.00.00</b>	<b>Serial #: 00013</b>
<b>VIDEO SCREEN TESTS</b>	
<b>EXIT</b>	
<b>COLOR ADJUSTMENT</b>	
<b>SCREEN SIZE ADJUSTMENT</b>	
<b>RED SCREEN</b>	
<b>GREEN SCREEN</b>	
<b>BLUE SCREEN</b>	
<b>WHITE SCREEN</b>	
<b>USE VOL UP &amp; VOL DN TO MOVE    TEST TO SELECT</b>	

- Color Adjustment** - Displays color bars to allow you to adjust the coloration of the monitor.
- Screen Size Adjustment** - Displays an image to allow you to change the size of the image on the monitor to make it fit properly.
- Red Screen** - Displays a full red screen for the purposes of adjusting the color of the screen.
- Green Screen** - Displays a full green screen for the purposes of adjusting the color of the screen.
- Blue Screen** - Displays a full blue screen for the purposes of adjusting the color of the screen.
- White Screen** - Displays a full white screen for the purposes of adjusting the color of the screen.

# DIAGNOSTIC, ADJUSTMENT AND AUDIT MENU SYSTEM

**Power Surge 01.00.00**

**Serial #: 00013**

**SOUND TESTS**

**EXIT**

**MUSIC TEST**

**SPEAKER TEST**

**100 Hz**

**1000 Hz**

**10000 Hz**

**USE VOL UP & VOL DN TO MOVE    TEST TO SELECT**

**Music Test** - Plays music from the game to ensure proper functionality.

**Speaker Test** - Test the stereo field to ensure both the left and right speakers are functioning properly.

**100 Hz** - Plays a tone of 100Hz to ensure the speaker is functioning properly.

**1000 Hz** - Plays a tone of 1000Hz to ensure the speaker is functioning properly.

**10000 Hz** - Plays a tone of 1000Hz to ensure the speaker is functioning properly.

# DIAGNOSTIC, ADJUSTMENT AND AUDIT MENU SYSTEM

<b>Power Surge 01.00.00</b>		<b>Serial #: 00013</b>
<b>Selection Lights</b>	<b>Dispensers</b>	<b>Blinkers</b>
<b>OFF</b>	<b>OFF</b>	<b>OFF</b>
<b>1</b>	<b>1</b>	<b>UPPER STROBE</b>
<b>2</b>	<b>2</b>	<b>LOWER STROBE</b>
<b>3</b>	<b>3</b>	<b>PRIZE STROBE</b>
<b>4</b>	<b>4</b>	<b>CABINET ROPE</b>
<b>5</b>	<b>5</b>	<b>START BUTTON</b>
<b>6</b>	<b>6</b>	<b>SELECT BUTTON</b>
<b>7</b>	<b>7</b>	<b>MONITOR ROPE</b>
<b>8</b>	<b>8</b>	
<b>9</b>	<b>9</b>	
<b>10</b>	<b>10</b>	

**USE KNOB TO MOVE THROUGH MENU.  
PRESS CONFIRM TO TEST.  
PRESS VOL UP & DN TO EXIT.**

**Selection Lights** - Test each set of selection lights next to each Prize Dispenser.

**Dispensers** - Test the functionality of each Prize Dispenser motor.

**Blinkers** - Test the functionality of all other cabinet lights.

# GAME REPAIR

WARNING: ALWAYS REMOVE POWER FROM THE GAME BEFORE ATTEMPTING ANY SERVICE, UNLESS NEEDED FOR SPECIFIC TESTING. FAILURE TO OBSERVE THIS PRECAUTION COULD RESULT IN SERIOUS INJURY TO YOURSELF AND / OR OTHERS.

## TROUBLESHOOTING PHILOSOPHY

To find problems with the game, always check the obvious first. See that the game is plugged in and that all of the fuses are good.

Next, check to see that all of the connectors are firmly seated and that no wires have been pulled out.

When trying to find out if specific components are bad or not, try swapping them with components from another **POWER SURGE™** game, if available, to see if the problem moves with the component or stays where it was. This will help you decide if you have a problem with a specific component or maybe a problem with either the wiring or the main p.c. board. Use extreme caution when using probes or volt meters if the game is powered up. If checking continuity, it is important to disconnect the harnessing at both ends, as attached they may yield erroneous results.

If a p.c. board is suspected as causing your problems, check to see that all of the I.C. chips are firmly seated on the board.

## MAIN P.C. BOARD REPLACEMENT

See page 30

1. Remove all A.C. power from the game
2. Unlock and remove the rear lower door.
3. Carefully remove all of the connectors from the main p.c. board.
4. Remove the long plastic hexagon nuts that secure the board to the main board housing.
5. Gently pull the p.c. board from the mounting studs.
6. Reassemble in the reverse order using a new main p.c. board.

## FRONT GLASS REPLACEMENT

See page 28

## SIDE GLASS REPLACEMENT

See page 29

## CONTROL PANEL BUTTON REPLACEMENT

See page 31

## MERCHANDISER REPLACEMENT

See page 26-27

## MARQUEE LIGHT REPLACEMENT

See page 25

## PRIZE SENSOR REPLACEMENT

See page 32

## SCHEMATICS

See page

# CONTROL PANEL BUTTON REPLACEMENT



## TO REMOVE THE BUTTONS:

1. Use keys to open door.
2. Buttons can be removed by loosening the nut holding them in place.
3. The knob can be removed by loosening the set screw shown here, then removing the (4) screws.

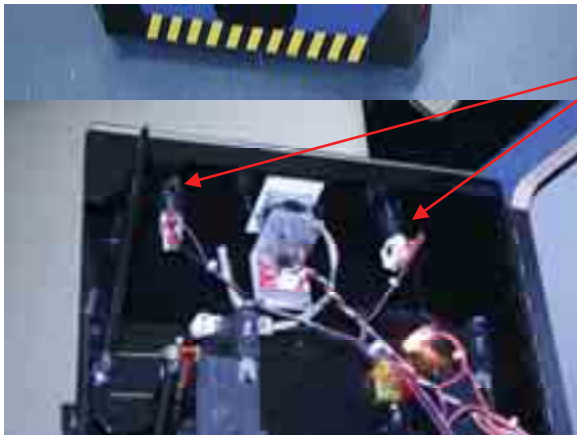

## TO REMOVE / REPLACE THE CONTROL PANEL DECAL:

1. Follow the steps above to remove the buttons.
2. Once the buttons and knob have been removed, the control panel should be easily removed.



ITEM NO.	PART NO.	DESCRIPTION	QTY.
1	PR3002	CONTROL KNOB	1
2	WC2005	BUTTON (YELLOW OVAL)	2
3	PR7012	CONTROL PANEL ASSEMBLY	1
4			
5			
6			
7			

# MARQUEE LIGHT ASSEMBLY BULB REPLACEMENT

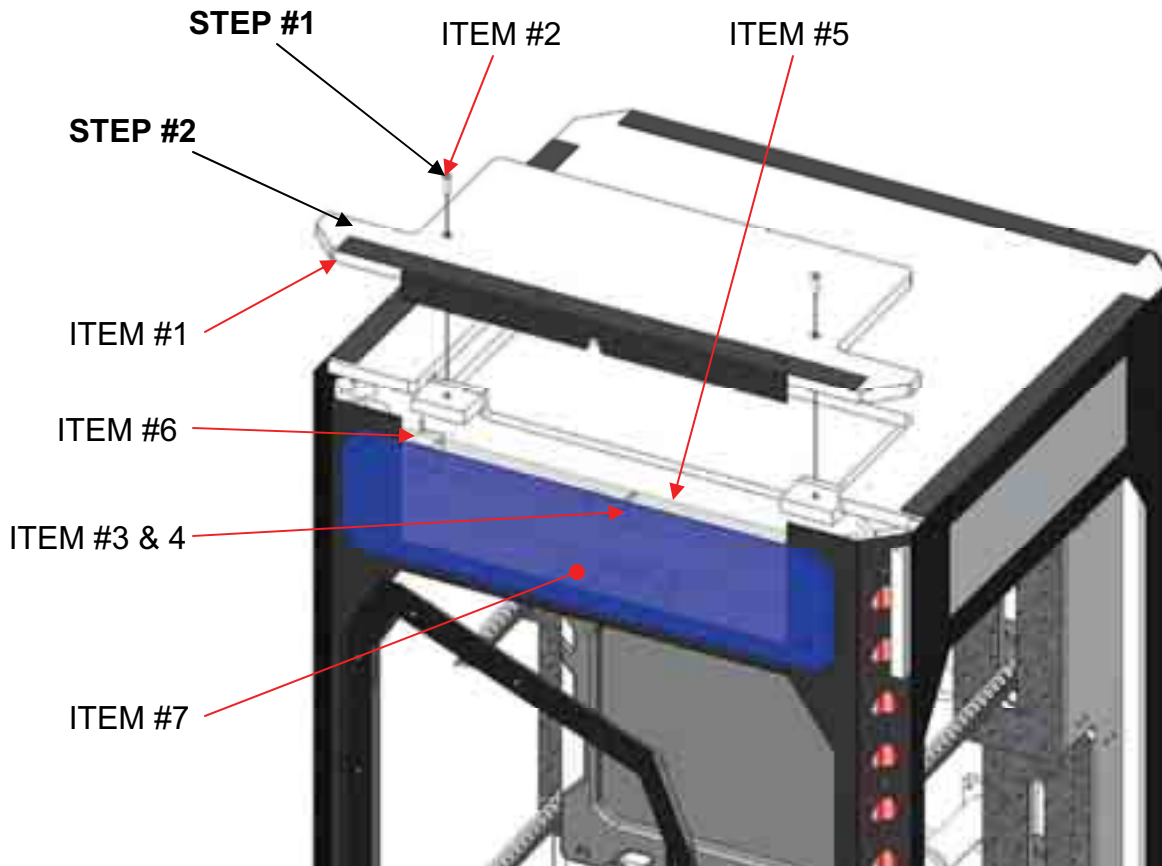

ITEM NO.	PART NO.	DESCRIPTION	QTY.
1	PR1024X	TOP EDGE COVER ASSY	1
2	6048	1/4-20 x 1" LG. BSHCS (ZINC)	2
3	BW2018	BULB PLASTIC SUPPORT	2
4	BW2017	BULB PLASTIC CLIP (1320-10)	2
5	8312	BULB (ROHS) PHILIPS PL-L 40W/41/RS/IS FLUORESCENT	1
6	BW250	LIGHT SOCKET	1
7	8449	BALLAST (MODEL #WH3-120-L)	1

STEP #1: Remove (2) 1/4-20 BSHCS.  
STEP #2: Remove (1) Top Edge Cover Assembly.

You should now be able to access the ballast or the bulb for maintenance.

STEP #3: Replace (1) Top Edge Cover Assembly.  
STEP #4: Replace (2) 1/4-20 BSHCS.

# MERCHANDISER REMOVAL/ADJUST.

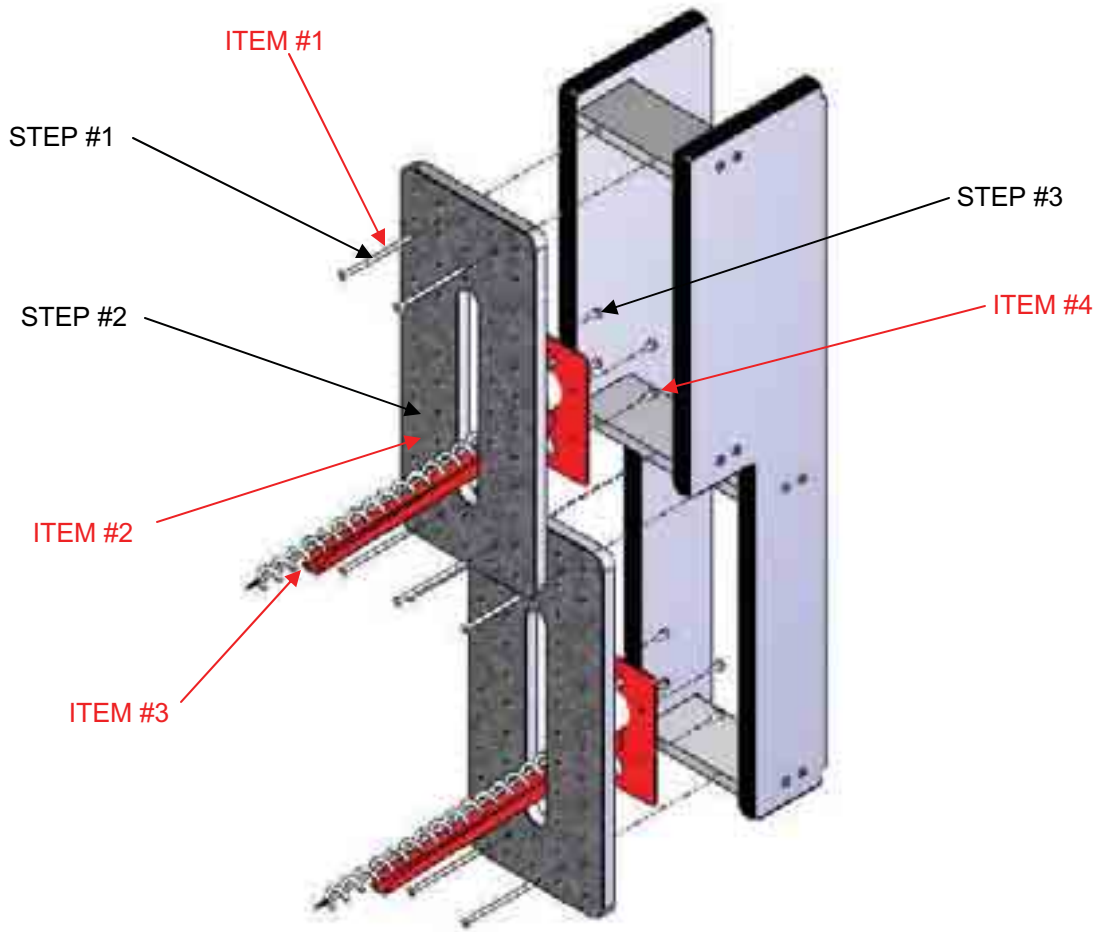

ITEM NO.	PART NO.	DESCRIPTION	QTY.
1	6626	8-32 x 3.0" LG PHMS	8
2	PR3059	PRIZE COIL PANEL	2
3	PR2000X	MERCHANDISER COIL	2
4	6068	8-32 x 3/8" LG PHMS	8
5			
6			
7			
8			

STEP #1: REMOVE (4) SCREWS.

STEP #2: REMOVE ENTIRE PANEL WITH MERCHANDISER ATTACHED.

STEP #3: REMOVE (4) SCREWS.

MOVE / REPLACE MERCHANDISER.

REPEAT IN REVERSE TO RE-ASSEMBLE.

# MERCHANDISER REMOVAL/ADJUST.

ITEM #5 (TYP)

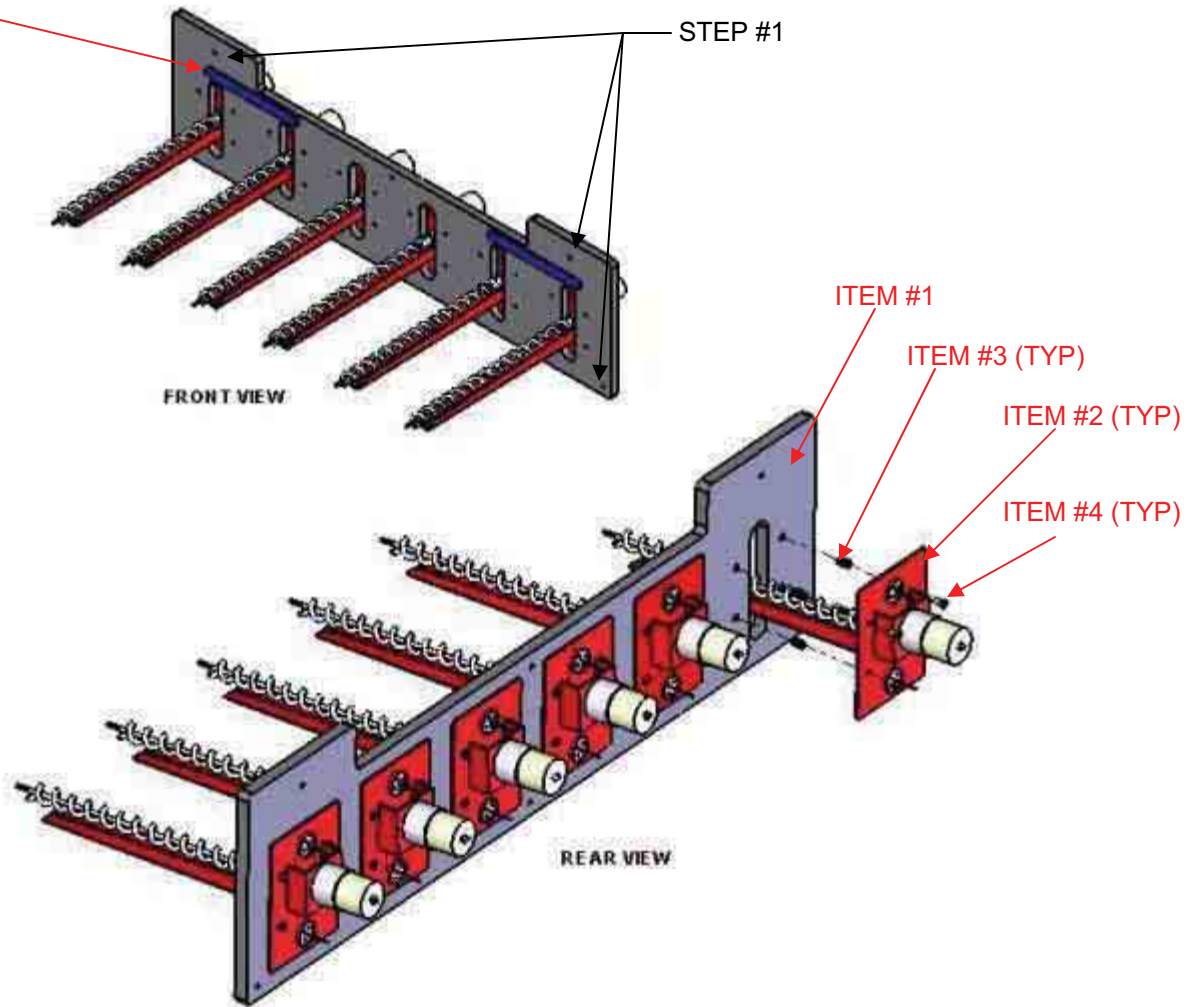

ITEM NO.	PART NO.	DESCRIPTION	QTY.
1	PR3071	LOWER COIL PANEL	1
2	PR2000X	MERCHADISER COIL	6
3	6489	8-32 INSERT (FLUSH)	24
4	6068	8-32 x 3/8" LG PHMS	24
5	PR7071	MINI-PRIZE DECAL	2
6			

STEP #1: REMOVE (4) SCREWS.

STEP #2: REMOVE ENTIRE PANEL WITH MERCHANDISER ATTACHED.

MOVE / REPLACE MERCHANDISER.

REPEAT IN REVERSE TO RE-ASSEMBLE.

# FRONT GLASS REMOVAL / REPAIR

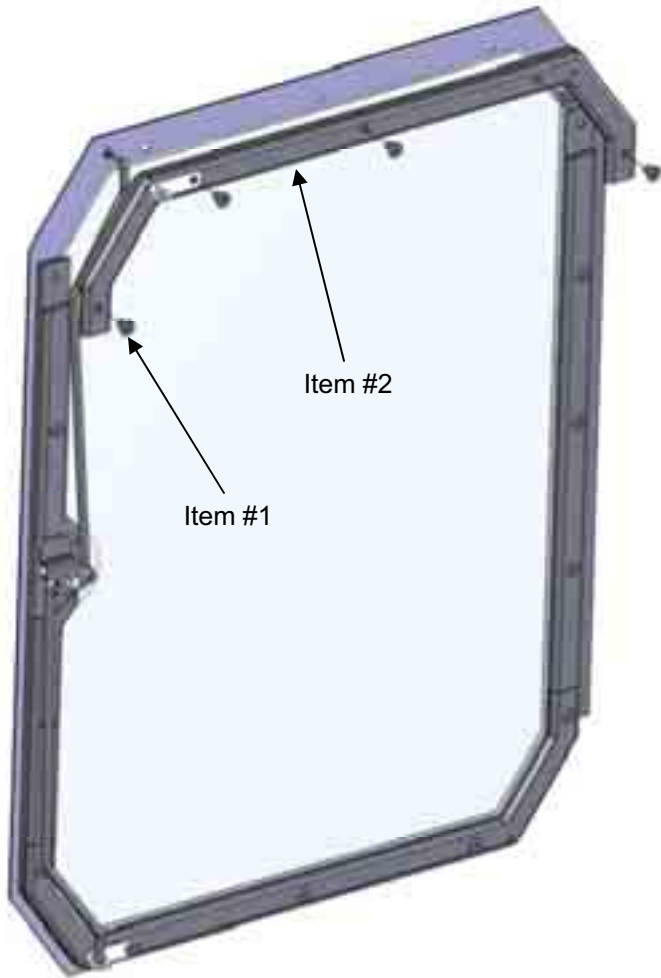

## Steps to follow for glass removal:

1. Remove all A.C. power from the game..
2. Use keys to unlock door.
3. Remove the (5) 1/4-20 Joint Connectors holding the top glass frame in place.
4. Remove the top glass frame.
5. Loosen the (8) 1/4-20 Joint Connectors holding each side glass retainer in place.
6. If the glass is broken, be sure to remove all pieces from where the new glass will rest.
7. Slide glass up and out of door frame.
8. With proper ceiling height, slide new glass in from the top. NOTE: be careful to properly align the glass with the side channels to prevent breakage.
9. When the glass is properly seated, tighten the (8) 1/4-20 Joint Connectors you loosened in Step #5.
10. Re-install the top glass frame using the (5) 1/4-20 Joint Connectors removed in Step #3.
11. Make sure all connectors are tightened fully.

ITEM NO.	PART NO.	DESCRIPTION	QTY.
1	6444	1/4-20 x 15/32 JOINT CONNECTOR	16
2	PR3020	DOOR GLASS CLAMP (TOP / BOTOM)	1
3			
4			
5			

# SIDE GLASS REMOVAL / REPAIR

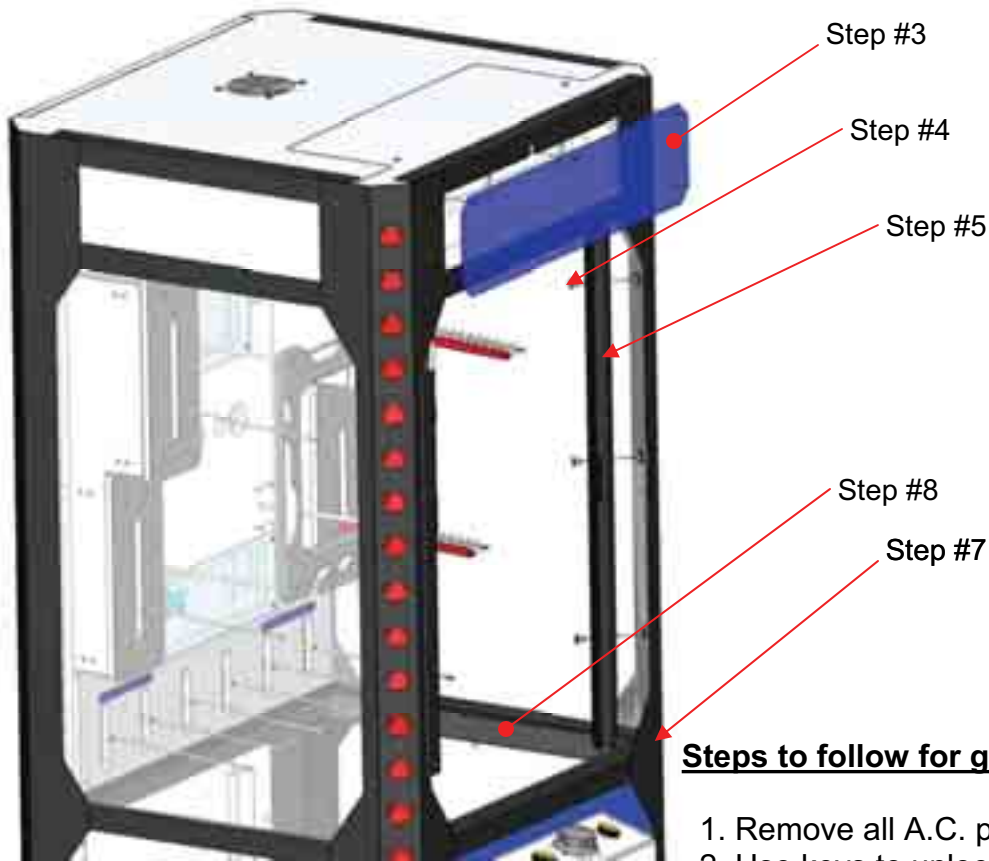

## Steps to follow for glass removal:

1. Remove all A.C. power from the game..
2. Use keys to unlock door.
3. Remove the (6) bolts holding the Marquee in place. You may have to open the top to access the hardware (see page #23). Remove the Marquee.
4. Remove the (3) 1/4-20 Joint Connectors holding the side cover in place.
5. Remove the side cover.
6. Remove the hardware holding Item #3 in place. (Make sure to remove the hardware from below the playfield as well).
7. Remove the Corner Assembly.
8. Remove the Bottom Glass retainer from underneath the playfield.
9. If the glass is broken, be sure to remove all pieces from where the new glass will rest.
10. Slide glass forward and out of door frame.
11. Slide new glass in from the front. NOTE: be careful to properly align the glass with the side channels to prevent breakage.
12. When the glass is properly seated, reassemble in reverse.
13. Make sure all connectors are tightened fully.

ITEM NO.	PART NO.	DESCRIPTION	QTY.
1	6444	1/4-20 x 15/32 JOINT CONNECTOR	16
2	PR3020	DOOR GLASS CLAMP (TOP / BOTOM)	1
3	PR1002X	CORNER ASSEMBLY	2
4			
5			

# PCB REMOVAL

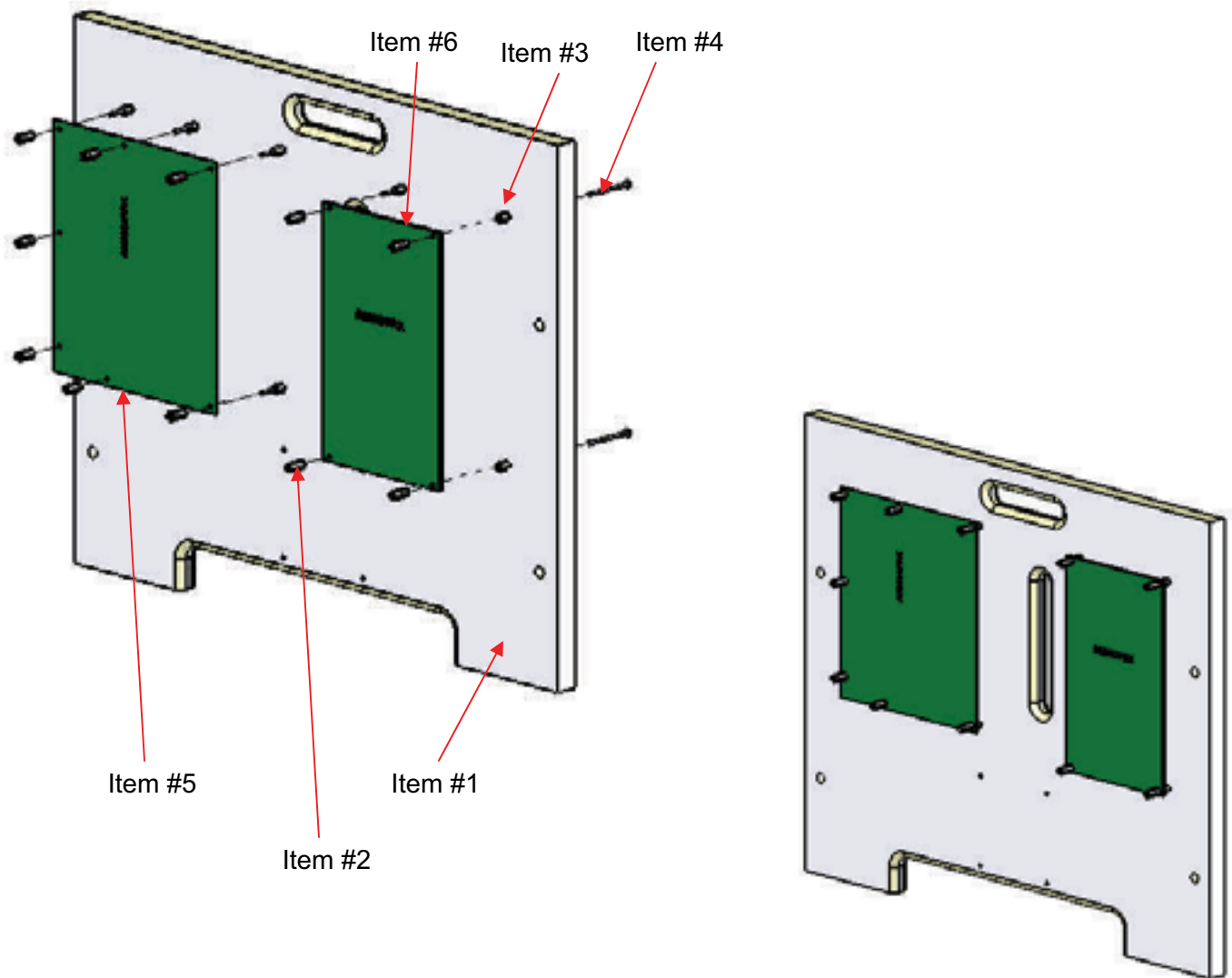

ITEM NO.	PART NO.	DESCRIPTION	QTY.
1	PR3086	ELECTRONICS PANEL	1
2	PC60641	6-32 X 5/8 HH SPACER	11
3	PC60642	6-32 x 3/8 HH SPACER	11
4	PC60628	6-32 x 1-3/4 PRHMS	11
5	RN2034PRX	POWER SURGE MAIN PCB	1
6	RB2037PRX	MARQUEE PCB	1

## Steps to follow for PCB removal:

1. Remove all A.C. power from the game..
2. Use keys to unlock door.
3. Remove the spacers (Item #2) that hold the PCB in place. Remove the PCB.
4. When the PCB is properly seated, reassemble in reverse.
5. Make sure all spacers are tightened fully.

# CONTROL PANEL BUTTON REPLACEMENT

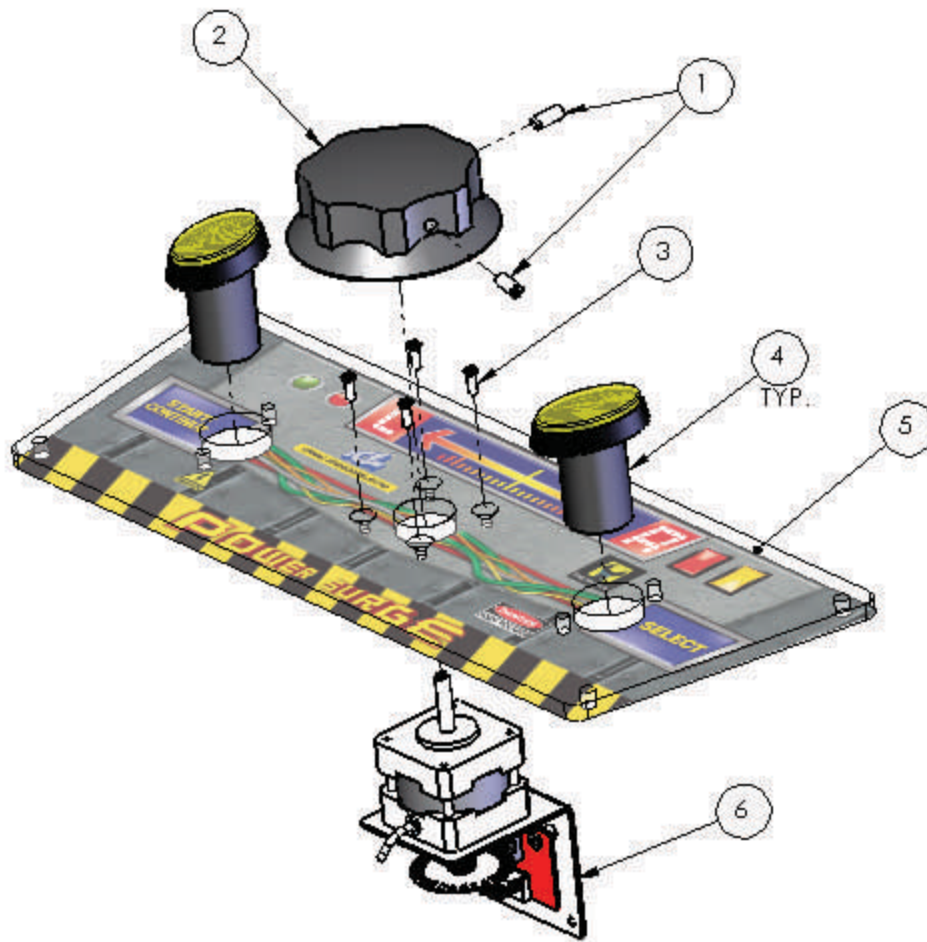

ITEM NO.	PART NO.	DESCRIPTION	QTY.
1	6384	SET SCREW	2
2	PR3002	KNOB	1
3	6370	4-40 x 3/8" LG. FHMS	4
4	WC2005	BUTTON (YELLOW OVAL)	2
5	PR7012	CONTROL PANEL	1
6	PR2010X	STEPPER MOTOR ASSEMBLY	1

# PRIZE SENSOR REPLACEMENT

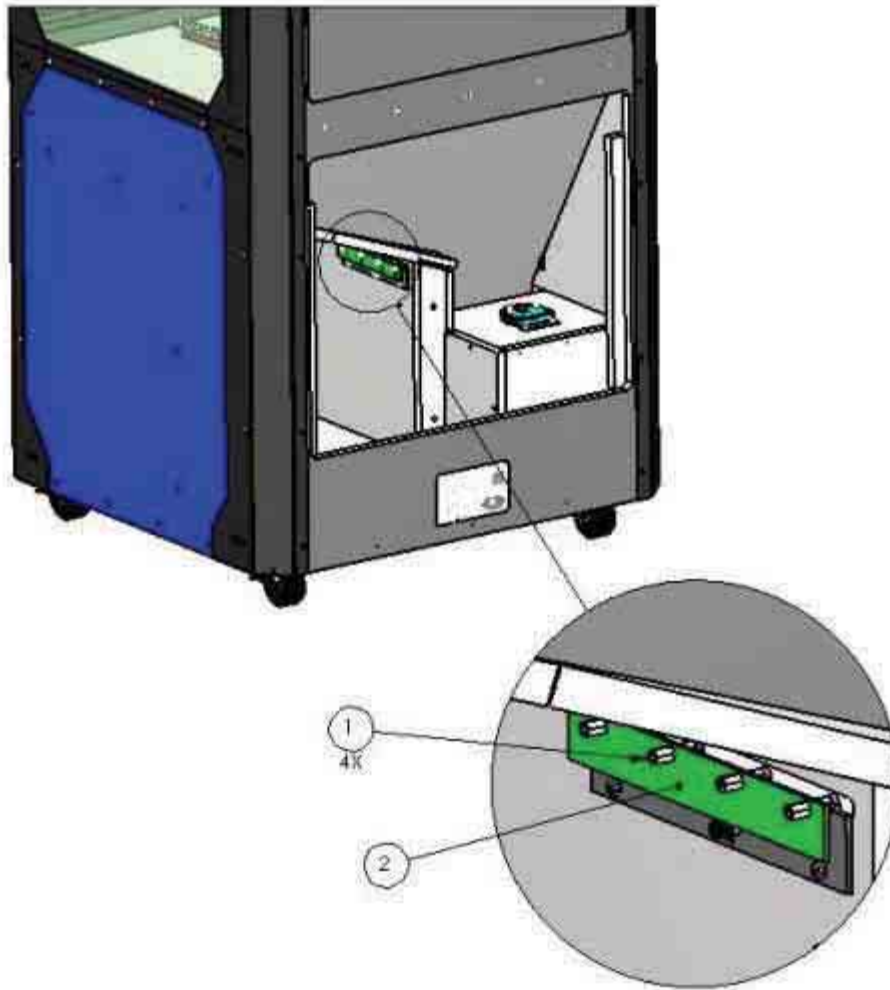

## **Steps to follow for Prize Sensor removal:**

1. Remove all A.C. power from the game..
2. Use keys to unlock door.
3. Remove the spacers (Item #2) that hold the PCB in place. Remove the PCB.
4. When the PCB is properly seated, reassemble in reverse.
5. Make sure all spacers are tightened fully.

ITEM NO.	PART NO.	DESCRIPTION	QTY.
1	PC60642	6-32 X 3/8" HH SPACER	4
2	PR2039X	PRIZE SENSOR PCB	1
3			

# PARTS LISTINGS

## Misc. Parts

5001D	Coin Door Set
CG1052	3" Locking Caster Wheel
PR3005	Corner Light Filter
PR3007	Monitor Bezel
PR3017	Prize Chute Door
PR3024	Side Glass
PR3025	Front Door Glass
PR7012	Control Panel

## Electrical Parts

8312	Marquee Light Bulb
AR2007	6 x 9 Speaker
CG2027	Power Cord 9'10"
CS3025	Prize Sensor Mirror
CS8449x	Ballast
FP2007	4" Round Speaker
MON19LCD	19" LCD Display
MS2364x	Fan Assembly
MZ2035x	Strobe Clear Flat Mount
PR2011x	Stepper Motor
PR2012x	Power Supply
PR2000x	Prize Dispensing Screws
PR2039x	Prize Sensor PCB
PR3002	Control Panel Knob
RB2037PRx	Marquee PCB
RN2034PRx	Power Surge Main PCB
SR2035	Opto Encoder Board
SR2038	Opto Encoder Wheel
WA1007x	Assembly (Reset Button)
WC2005	Yellow Oval Button

## Graphics and Decals

PR7012	Decal-Control Panel Overlay
PR7017	Decal-Prize Door Graphic
PR7027	Decal-Marquee
PR7059	Decal-Power Prize Decal
PR7071	Decal-Mini-Prize Decal



# Warranty

I.C.E warrants all components in the **Power Surge™** game to be free of defects in materials and workmanship for a period of ninety days from the date of purchase.

This warranty does not cover items damaged due to normal wear and tear, subjected to abuse, improperly assembled by the end user, modified, repaired, or operated in a fashion other than that described in the service manual.

If your **Power Surge™** game fails to conform to the above-mentioned warranty, I.C.E.'s sole responsibility shall be at its option to repair or replace any defective component with a new or remanufactured component of equal to or greater O.E.M. specification.

I.C.E. will assume no liability whatsoever, for costs associated with labor to replace defective parts, or travel time associated therein.

I.C.E.'s obligation will be to ship free of charge, replacement parts by U.P.S. Ground, U.S. mail, or other comparable shipping means. Any express mail or overnight shipping expense is at the cost of the purchaser.

Products will be covered under warranty only when:

- The serial number of the game with the defective parts is given. A tech number has been issued by an I.C.E. technical representative.
- The serial number of the defective part, if applicable, is given.
- Defective parts are returned to I.C.E., shipping pre-paid, in a timely fashion, if requested by I.C.E.
- A copy of the sales receipt is available as proof of purchase upon request of I.C.E.

I.C.E. distributors are independent, privately owned and operated. In their judgment, they may sell parts or accessories other than those manufactured by I.C.E. We cannot be responsible for the quality, suitability, or safety of any non-I.C.E. part, or any modification, including labor, which is performed by such a distributor.



# WARRANTY

ICE Inc warrants that all of its products will be free from defects in material and workmanship.

When placing a warranty request, please be prepared to provide the following information:

- Serial Number of Game or Bill of Sale
- Machine Type
- A Detailed Description of the Equipment Fault Symptoms

ICE product, including Cromptons, Sam's Billiards, Uniana and Bell Fruit is warranted as follows:

- 180 days on the Main PCB and Computers
- 180 days on motors
- 90 days on all other components (i.e. DBV's, Ticket Dispensers, sensors, etc)
- 30 days on all repaired items
- 3 years on all Crane Harnessing
- 180 days on monitors
- 9 Months on Printers

ICE Inc shall not be obligated to furnish a warranty request under the following conditions:

- Equipment has been subjected to unwarranted stress through abuse or neglect
- Equipment has been damaged as a result of arbitrary repair/modification attempts
- Equipment that has failed through normal wear and tear

ICE Inc will assume no liability whatsoever for costs associated with labor to replace defective parts or travel time associated therein.

All defective warranty covered components will be replaced with new or factory refurbished components equal to OEM specifications. ICE Inc will cover all UPS ground, or comparable shipping means, freight costs during the warranty period. Expedited shipments are available for an additional charge.

Defective parts are returned to ICE Inc, at the customer's expense, in a timely fashion.

ICE distributors are independent, privately owned and operated. In their judgment, they may sell parts and/or accessories other than those manufactured by ICE Inc. We cannot be responsible for the quality, suitability or safety of any non-ICE part, modification (including labor) that is performed by such a distributor.

I.C.E. Parts/Service Dept.  
Innovative Concepts in Entertainment  
10123 Main St.  
Clarence, NY 14031  
Phone #: (716) - 759 - 0360  
Fax #: (716) - 759 - 0884