

# Pac-Man Ball 2p

## Installation Supplement

### Read this supplement before installation

The major attraction of this game is the provision of high volumes of coins flowing in and out so it is crucial to adjust accurately game features. The game concept with the embedded video game provides increased coin drop onto the pusher table. For every 100 coins inserted an average total of 180 coins are deposited on the pusher table.

It must be remembered that the successful and profitable operation of this machine depends on the correct adjustment of the game to suit the location.

Adjustment of the front edge to achieve the correct percentage is necessary after initial machine installation to suit the environment. The machines are set at the factory on an approximate setting to suit the guidelines but as with any pusher it must be accurately monitored to achieve the desired play appeal yet provide the correct return.

The machine % payout is determined with a combination..  
of the Intermediate payout from video game (180%)..  
and the playfield payout (adjustable)

To suit the UK guidelines this guide shows the accepted limits for payout adjustments.

The 2pence machine can be adjusted to either 50 coins or 250 coin maximum drop from the video game. (the actual intermediate payout will always be 180%)  
(See the Operators Manual section 5-7-2 'Options' page 58)

When adjusting.....

- Always keep a record of the gauge setting and the achieved percentage, the payout percentage can only be controlled if it is monitored and recorded.
- Adjust the gauge by first moving the bar to the extreme right hand edge, then drag back to the new setting.

For all Parts or Technical Support contact:

Brent Electronic,  
[www.brentelectronic.co.uk](http://www.brentelectronic.co.uk)

For Technical Support, Warranty and

Advance Replacement Parts:-

 +44 (0) 20 8324 6120

For Consumable Parts:-

 +44 (0) 20 8324 6102

Fax for both:-

 +44 (0) 20 8324 6126

## Notes on Installation

**WARNING** • NEVER turn the power to the machine ON until installation has been completed.

**WARNING** • In order to prevent possible electric shocks, be sure that the machine is connected to the mains with a securely connected earthed plug.

**CAUTION** • In order to avoid damage to the machine due to mis-operation, ensure that the voltage of the mains supply is 230volts AC.

**NOTE** • In order to gain access to the Power Supply and CPU assemblies, make sure that the rear of the machine is separated from a wall or other machine by at least 500mm.

## Lowering the Level Adjusters

1. When the game is in it's final position, lower the four (4) level adjusters with a spanner, so that all castors are raised from the floor by approx 5mm. Tighten the lock nuts with a spanner to ensure that the Level Adjusters do not move.

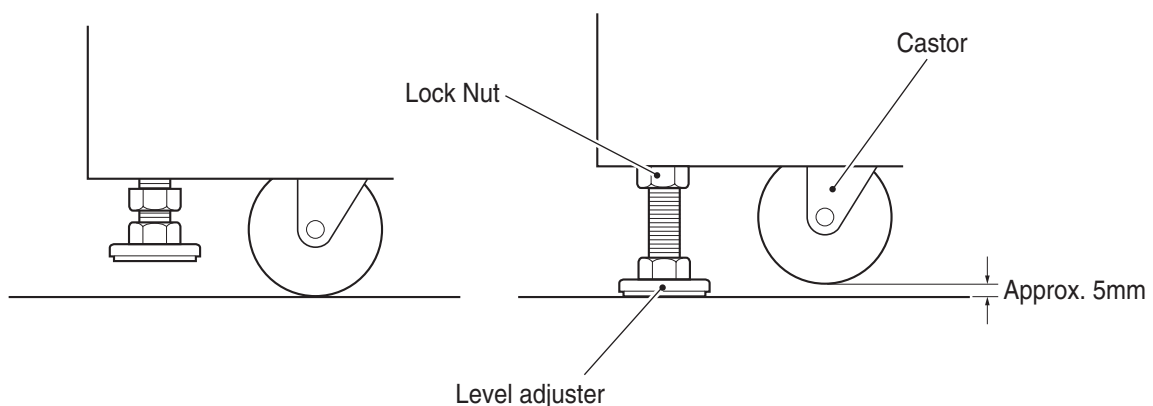

## Adjusting the Tilt Sensitivity

The machine is equipped with a tilt device. If the machine is shaken excessively, the tilt device activates an alarm sound and closes the divider of the Payout Assy to prevent coins falling to the payout tray.

*To reset the game after the tilt has been activated see the Operators Manual section 5-3 page 46*

1. Remove 6 off pozihead screws (M4x30) and remove the Rear Door.
2. Loosen the grub screw (M3x6) on the weight, and slide the weight up or down to adjust the sensitivity. Moving the weight up will decrease sensitivity and moving the weight down will increase sensitivity. Re-tighten the grub screw (M3x6).
3. By loosening 2 off pozihead screws, the actuator bracket can be moved to ensure that the weight is central to the actuator.  
*If the actuator bracket cannot be adjusted so that the weight is central, the machine is not level. Adjust the level adjusters, until the machine is level. (see the Operators Manual section 4-2 page 36)*

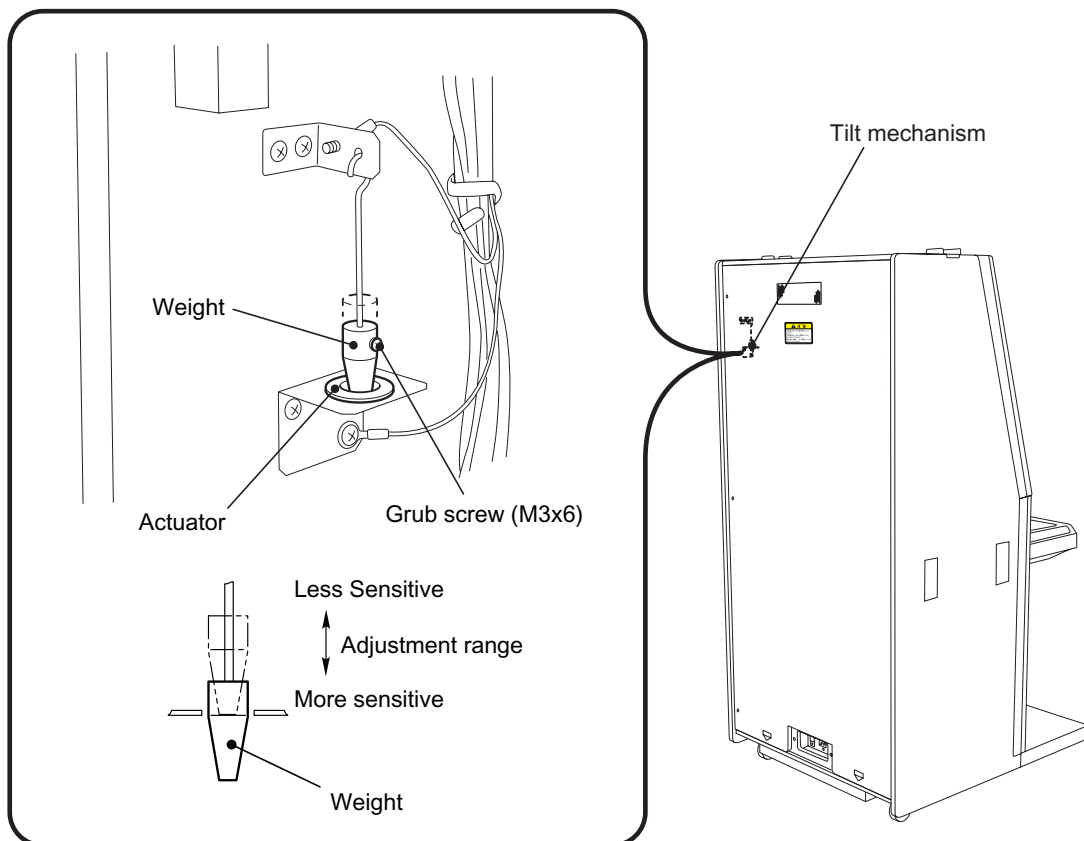

## Loading with Coins

### Loading Coin Hopper (C)

1. Unlock and open the playfield door, and drop coins through the coin inlet.
2. After loading the hopper (C) close and lock the playfield door.

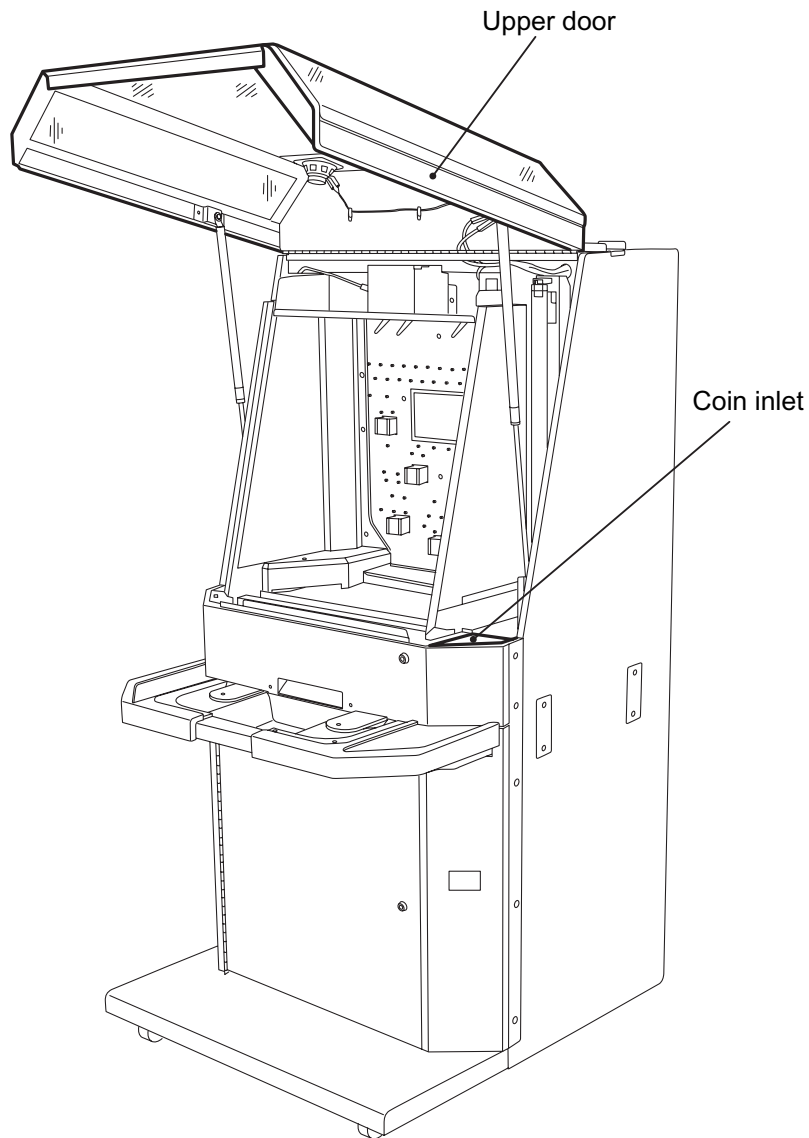

#### Note:

- **The machine counts supplied coins only. Accurate H/G (house gain) cannot be obtained unless enough coins are supplied until coins start falling into the cashbox. Be sure to supply enough coins until coins start falling into the cashbox.**
- **The capacity of Coin Hopper (C) is approximately 500 x 2p coins.**
- **Do not use dirty, damaged or severely scratched coins, as they may cause coin jamming.**

## Loading Coin Hoppers (L) and (R)

1. Unlock and open the maintenance door, and supply coins directly to the coin hoppers (L) and (R).
2. After loading the hoppers (L) and (R) close and lock the maintenance door.

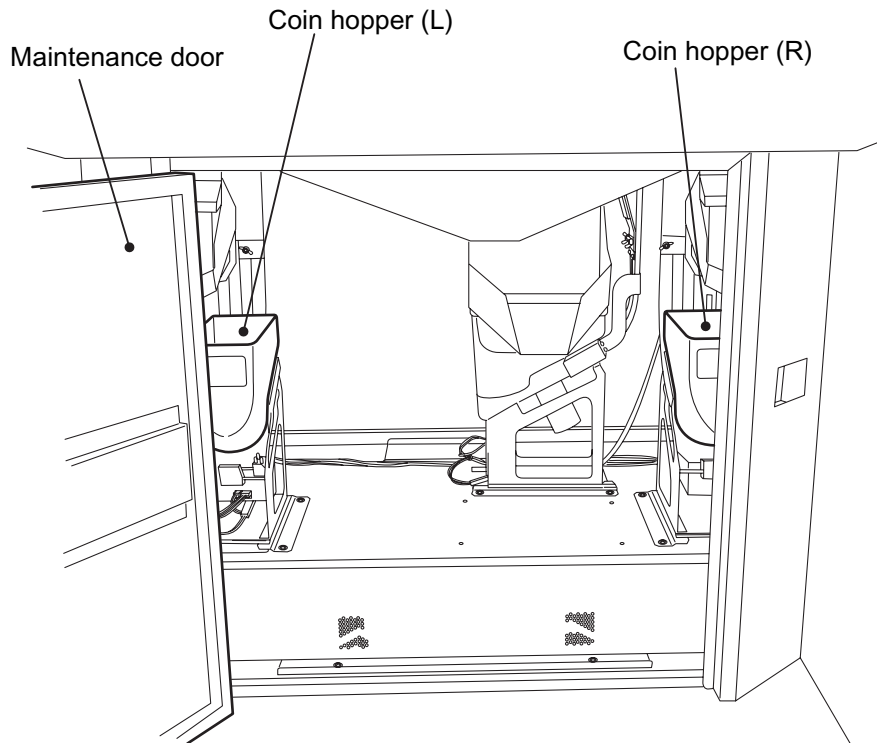

### Note:

- These hoppers are used to supply coins to the playfield. Supply **£5.00 of 2p coins** to each of the hoppers (L) and (R). If too many coins are added, excessive load is applied to the motor which can shorten the working life of the coin hoppers.
- **If a “1-13 or 1-23 Coin Hopper (L), (R) Empty” error occurs frequently, (except in the case of a jammed coin or empty hopper), increase the amount of coins within the above levels. This may reduce the frequency of error generation.**
- **Do not use dirty, damaged or severely scratched coins, as they may cause coin jamming.**
- When the game is played for the first time after installation, a Hopper Empty error may occur. This error is generated because the game has not sensed a coin being fed to the playfield within a certain period of time. This is because of the time taken for the escalator to fully fill, and is not a malfunction. Cancel the error by referring to the Operators Manual section 6-3-4 ‘Resetting errors’ page 96.

## Loading the Playfield

1. Unlock and open the Playfield door. Evenly distribute coins on both the Pusher and Playfield.

**The recommended amount to load is: £15.00 in 2p coins - minimum £12.00**

2. After loading the Playfield, close and lock the Playfield door.

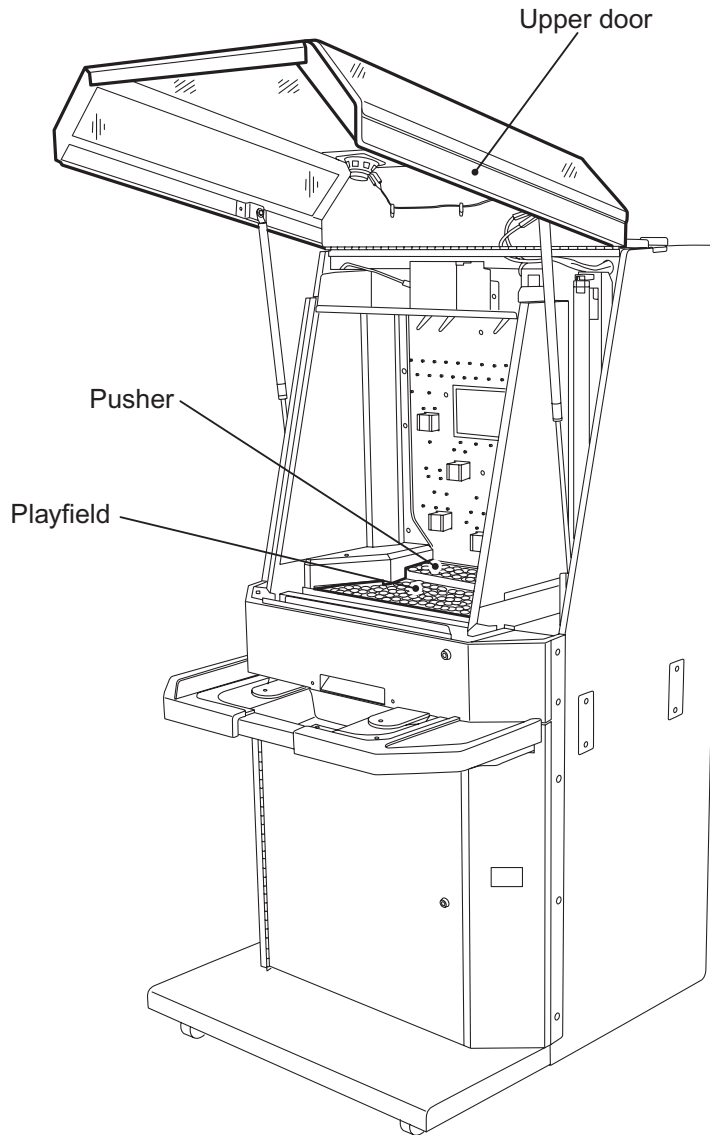

### Note:

- This game is designed for coins only. Do not place prizes on the playfield as these can become stuck and cause a jam when falling to the payout tray.
- Do not use dirty, damaged or severely scratched coins, as they may cause coin jamming.

The payout rate may change suddenly in a new machine due to wearing-in caused by coins in the initial period of operation and the natural stacking of coins on the playfield. To maximise income, it is very important that following the installation of this game, the payout rate is checked regularly, and when necessary adjusted. (see the Operators Manual section 5-7-7-3 page 65 'Field Payout measurement mode' and section 5-1 page 43 'Adjustment of the Payout Rate')

Even after the game has been operating for some time, it is advisable to regularly check and adjust the payout rate as the following can all cause the payout rate to change.:

<b>Coin Factors</b>	<b>Coin diameter, coin thickness, coin weight and coin surface patterns.</b>
<b>Environmental Factors</b>	<b>Temperature, humidity and the level of the machine.</b>
<b>Age Related Factors</b>	<b>Dirtiness of Coins, dirtiness of the Playfield and scratches to the Playfield.</b>

It is recommended that the Payout is set to approx:

**72% (Field Payout Rate: 40%)**

If the payout is set too low, the game may generate a higher profit for a given number of coins played, but may deter repeat players. With the payout set higher, the profit may be less but the game can attract more players generating a higher turnover. This is especially true in a site with regular customers.

## Adjustment of the Payout Rate

### Adjustment of the Front Edge

By adjusting the vertical position of the front edge of the playfield, the field payout rate - (the ratio of the number of coins dispensed to the playfield to the sum of coins inserted and coins discharged from the coin hopper (C)) can be varied.

When the front edge is raised, the playfield rate decreases and when the front edge is lowered the rate increases.

1. Unlock and open the Playfield door.
2. Remove 1 off socket head screw (M4x6) and remove the left side cover.
3. Loosen 2 off socket head screws (M4x6) and remove the top.

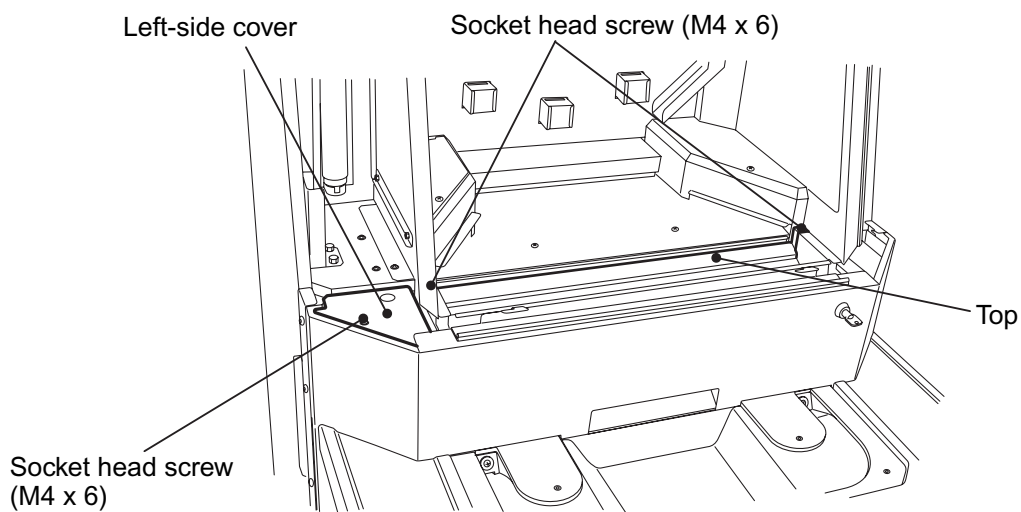

4. Loosen 3 off socket head screw (M4x14)

**Note:** Do not remove these screws, as internal parts will become detached and fall out of place.  
Ensure that the screws are re-tightened after adjustment

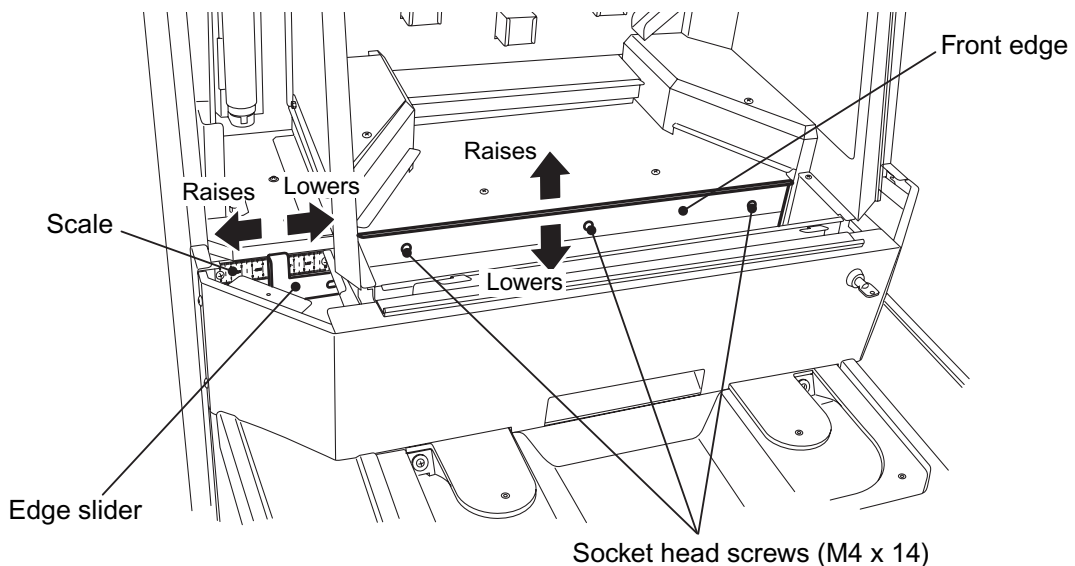

5. Move the edge slider fully to the right, (to remove any slack), and then move it to the left to the required position to adjust the height of the front edge.

**The edge slider MUST first be moved fully to the right to ensure accurate adjustment.**

*Moving the edge slider to the left by 1mm raises the front edge by 0.1mm and moving the edge slider to the right 1mm lowers the front edge by 0.1mm.*

6. Retighten the 3off socket head screws (M4x14)

**To suit Uk requirements the adjustment guage should be only be adjusted between 30.0 and 34.5.**

### Measurement of the Field Payout Rate

- An approximate Field Payout Rate can be made by using the “Field Payout Rate measurement Mode” in the test mode. (see the Operators Manual section 5-7-3-3 page 65)
- It is recommended that the scale value, measured data, and date of measurement are retained for future comparisons.

Note:

**The edge slide scale value is only a guide. The actual field payout rate should be calculated by the equation:**

**$Coins\ Out \div (Coins\ In + Hopper\ (C)\ Out) = Measured\ field\ payout\ rate\ (\%)$**

### Basic Payout Rate

The Payout Rate is the ratio of the ‘number of coins paid out’ to the ‘total number of coins inserted’.

The following table provides the data of theoretical payout rates based on the field payout rate.

FIELD P/O	36%	38%	<b>40%</b>	42%	44%	46%	48%	50%	52%	54%
PAYOUT	64.8%	68.4%	<b>72.0%</b>	75.6%	79.2%	82.8%	86.4%	90.0%	93.6%	97.2%

It is recommended that the Payout is set to approx 72% (Field Payout Rate: 40%)

If the payout is set too low, the game may generate a higher profit for a given number of coins played, but may deter repeat players.

With the payout set higher, the profit may be less but the game can attract more players generating a higher turnover. This is especially true in a site with regular customers.

## Adjustment of the Side Edges

- There is normally no need to adjust the side edges In normal operation.
  - The side edges are factory set to the furthest end.
1. Unlock and open the Playfield Door.
  2. Remove 1 off pozihead screw (M4x6) from each Stage Plate and remove the Stage Plates L & R.

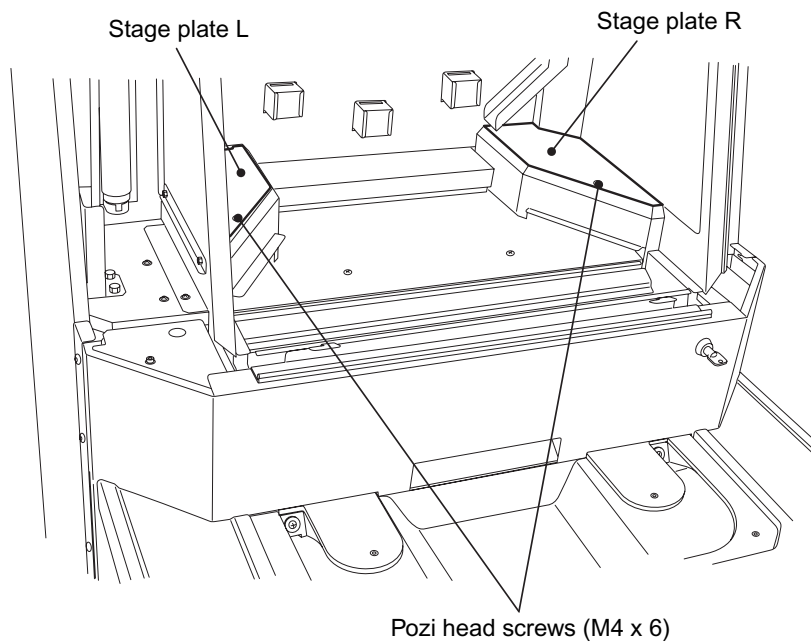

3. Loosen the 2 off cap screws (M4x20) and move the Side Edges (L), (R) forwards or backwards for adjustment.

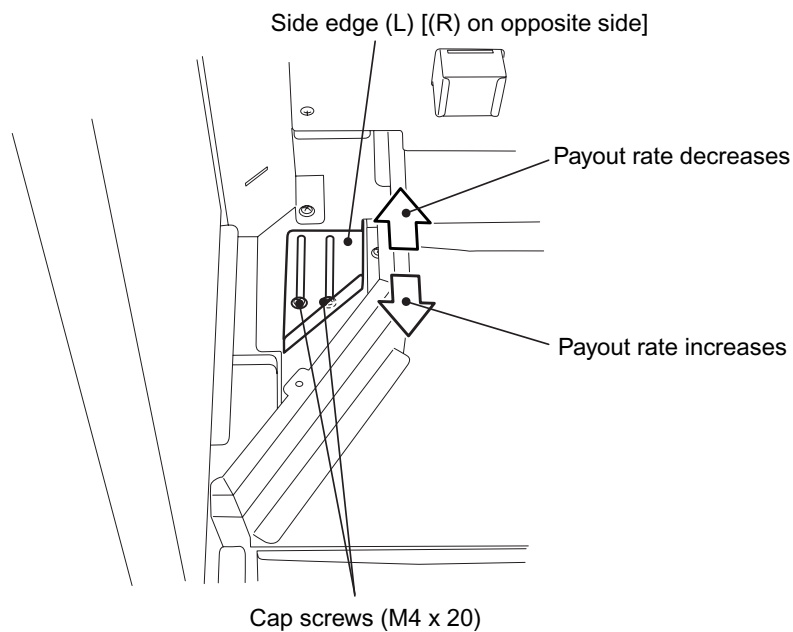

4. Re-assemble in reverse order.

## Resetting the Tilt

The tilt device can be reset in two ways: manual reset performed by a member of staff, or automatic reset.

It is also possible to disable the tilt function.

The method of changing the setting is described in Operators Manual section 5-7-2 page 58.

To adjust the tilt sensitivity refer to the Operators Manual section 4-3 page 37.

- **Manual Reset**

1. Unlock and open the Playfield Door.
2. Turn the Test switch, located in the upper right corner of the cabinet, On and then Off to reset the alarm.

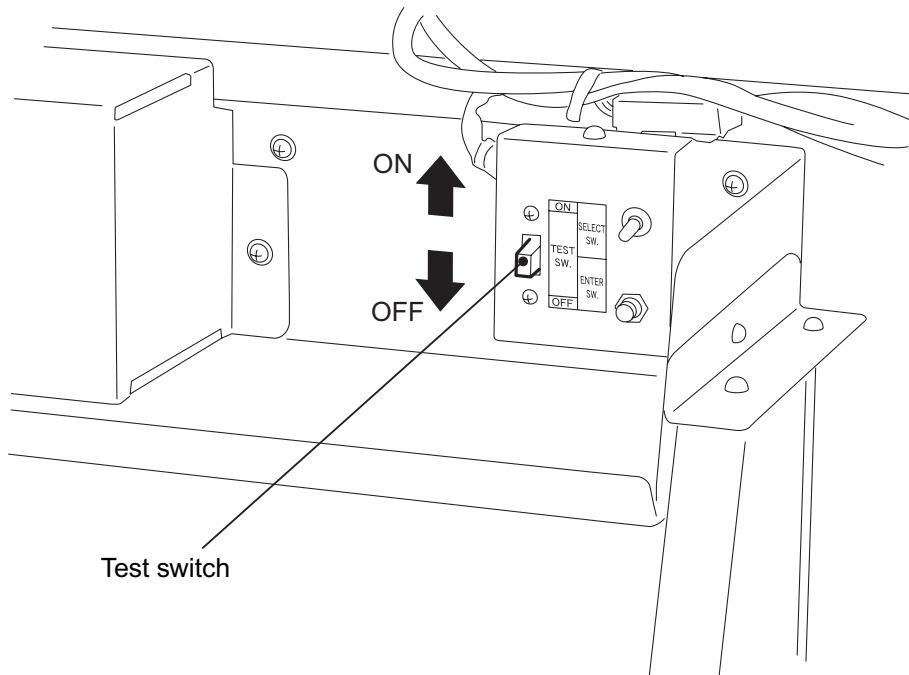

3. Close and lock the Playfield Door.

- **Automatic Reset** (default setting)

When the tilt is set to automatic reset, the alarm will reset 10 seconds after it has been activated.

