



## OPERATOR'S MANUAL



## **Important**

**Read PRECAUTIONS and INSTALLATION Sections before operating game**

## **FCC Notice**

Note: This equipment has been tested and found to comply with the limits for a Class A digital device, pursuant to Part 15 of the FCC Rules. These limits are designed to provide reasonable protection against harmful interference when the equipment is operating in a commercial environment. This equipment uses, and can radiate radio frequency energy and, if not installed and used in accordance with the instruction manual, may cause harmful interference to radio communications. Operation of this equipment in a residential area is likely to cause harmful interference in which case the user will be required to correct the interference at his own expense.

**Copyright 2004 TAITO CORPORATION. - All rights reserved**

No part of this publication may be reproduced by any mechanical, photographic, or electronic process, or in the form of a phonographic recording, nor may it be stored in a retrieval system, transmitted, or otherwise copied for public or private use, without permission from TAITO CORPORATION.

---

## TABLE OF CONTENTS

|   |           |
|---|-----------|
| <b>1.0 SPECIFICATIONS</b>                       | <b>4</b>  |
| <b>2.0 PRECAUTIONS</b>                          | <b>5</b>  |
| <b>2.1 INSTALLATION</b>                         |           |
| <b>2.2 HANDLING</b>                             |           |
| <b>3.0 INSPECTION</b>                           | <b>6</b>  |
| <b>4.0 INSTALLATION</b>                         | <b>6</b>  |
| <b>5.0 GAME PLAY</b>                            | <b>7</b>  |
| <b>5.1 HOW TO PLAY</b>                          |           |
| <b>5.2 WINNERS PRIZE SELECTION</b>              |           |
| <b>6.0 GAME SETTING MODE</b>                    | <b>7</b>  |
| <b>6.1 HOW TO ENTER THE GAME SETTING MODE</b>   |           |
| <b>6.2 HOW TO ADJUST THE GAME SETTING STYLE</b> |           |
| <b>6.3 LCD display chart 1</b>                  |           |
| <b>6.4 LCD display chart 2</b>                  |           |
| <b>6.5 ADJUST PRIZE SETTING</b>                 |           |
| <b>6.6 PROGRAMMABLE MODE</b>                    |           |
| <b>6.7 FACTORY DEFAULT SETTING</b>              |           |
| <b>7.0 PRIZES</b>                               | <b>14</b> |
| <b>7.1 RECOMMENDED PRIZE SIZES</b>              |           |
| <b>7.2 HOW TO FILL THE PRIZES</b>               |           |
| <b>7.3 ADJUSTING THE PRIZE SLIDE GUIDE</b>      |           |
| <b>8.0 OPERATE WITHOUT PRIZE VENDING ARM</b>    | <b>18</b> |
| <b>9.0 TEST MODE</b>                            | <b>19</b> |
| <b>9.2 LAMP TEST MODE</b>                       |           |
| <b>9.1 HOW TO START TEST MODE</b>               |           |
| <b>9.3 SENSOR AND SWITCH TEST MODE</b>          |           |
| <b>9.4 SOUND TEST MODE</b>                      |           |
| <b>9.5 MECHANICAL TEST MODE</b>                 |           |
| <b>10.0 PAYOUT DATA CLEAR</b>                   | <b>21</b> |
| <b>10.1 CLEAR EACH PRIZE ARM PAYOUT DATA</b>    |           |
| <b>10.2 CLEAR ALL PRIZE ARM PAYOUT DATA</b>     |           |
| <b>11.0 ERROR MESSAGE CHART</b>                 | <b>22</b> |
| <b>12.0 TECHNICAL REFERENCE</b>                 | <b>23</b> |
| <b>CABINET WIRING</b>                           |           |

## 1.0 SPECIFICATIONS

Input Power: 120 VAC, 60 Hz, 2 Amp 200 Watts Max (U.S. only)  
Installed Dims: 32" W 32" D 79" H  
Installed Weight: 400 Lbs



---

## 2.0 PRECAUTIONS

### 2.1 INSTALLATION

This game is designed for indoor use only. It must not be installed outdoors. The following conditions must be avoided.

1. Direct exposure to sunlight, high humidity, direct water contact, dust, high heat, or extreme cold.
2. The game must be installed on a level surface with levelers and/or casters in place to avoid vibration.
3. Do not place near hazardous, flammable, or chemical liquids.

Do not install in an area such that the game would present an obstacle in case of an emergency (i.e., near fire equipment or emergency exits).

### 2.2 HANDLING

1. Before operating the game, make sure that the main AC power hookup includes a safety ground. This will ensure safe operation as well as compliance with FCC and UL regulations. Measure the AC power line voltage. Verify that the voltage source is between 110 and 125 VAC.
2. Before replacing any parts, turn the AC power OFF and unplug the game.
3. When unplugging the game from an electrical outlet, always grasp the plug, not the line cord.
4. The game power supply includes areas of high voltage. Take care at all times to avoid electrical shock whenever inspecting or adjusting the game.
5. Do not attempt to repair the Printed Circuit Boards (PCBs) on-site. They contain sensitive integrated circuit chips that could be easily damaged, even by the small internal voltage of a multimeter. Always return the PCBs to your distributor for any repairs.
6. Always raise the leg levelers before attempting to move the game.

#### **WARNING**

**When packing PCB's for shipment, enclose in anti-static wrap. TAITO CORPORATION is not responsible for damage to components due to static discharge.**

### 3.0 INSPECTION

To ensure a successful startup following shipment, the CONVOY game cabinet should be inspected before initial power-up.

1. Carefully remove the game cabinet from its shipping platform and inspect it for visible signs of damage.

**If your game exhibits signs of damage, be sure to document it and contact your distributor and transportation carrier immediately.**

2. Remove the keys from the coin return. Open and remove the rear access panel.
3. Inspect the game's PCB, verifying that all connections are properly seated. Inspect the power supply area for any loose components.
4. Connect the main AC power cord and turn on the power.

#### **WARNING**

**Removal of serial numbers from product or components will be void the warranty.**

### 4.0 INSTALLATION

Note: Shipping damage may void the warranty. In case of shipping damage, contact your distributor and the transportation carrier immediately.

With the game in its installation position, lower the leg levelers.

## 5.0 GAME PLAY

### 5.1 HOW TO PLAY

Three tries per game. Press the brake button to stop the wheel.  
 If you tap the brake, you can come to a slow stop.  
 If you hold the brake, you will stop the wheel faster.  
 To win a prize, you must fill the gauge meter.  
 Note: "Random" gives you a positive number between 1 and 9.

### 5.2 WINNERS PRIZE SELECTION

- ① Choose a prize by pressing the "PRIZE SELECT BUTTON".  
 Letter will light up to show prize selection.
- ② Press the "BRAKE BUTTON" to dispense your prize.

## 6.0 GAME SETTING MODE

### 6.1 HOW TO ENTER THE GAME SETTING MODE

Press the ENTER switch on the service panel inside of the Coin Door to enter the GAME SETTING MODE. LCD display on the service panel shows current setting. (See example display below)

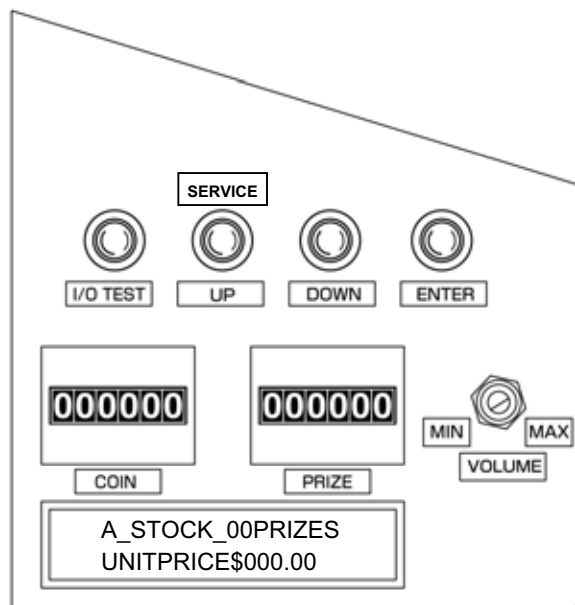

## 6.2 HOW TO ADJUST THE GAME SETTING STYLE

Advance each prize vending unit setting by pressing the DOWN Switch on the service panel.

Press the ENTER Switch to enter each Prize Vending Arm setting.

Change the setting by pressing the UP or DOWN Switch.

After you change the setting, press the ENTER Switch to return to the previous screen. Press the DOWN switch until Prize Arm A setting is displayed. (See example display below.)

Then the adjustment will be complete.

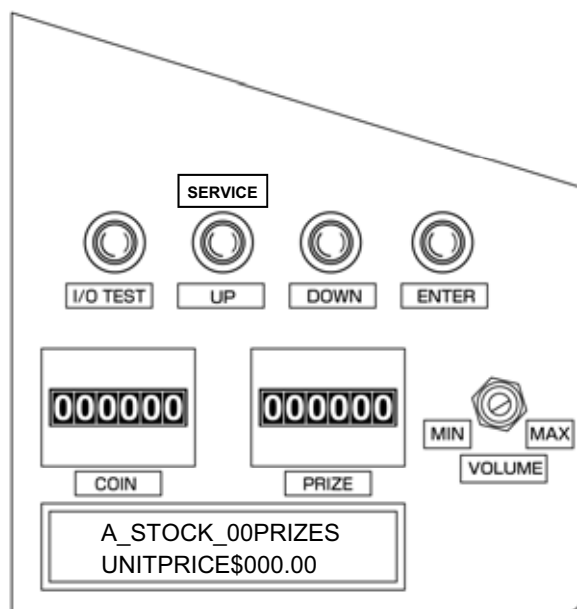



### 6.4 LCD display chart 2

Note: Chart shows "PAYOUT: EVERY ARM" setting.

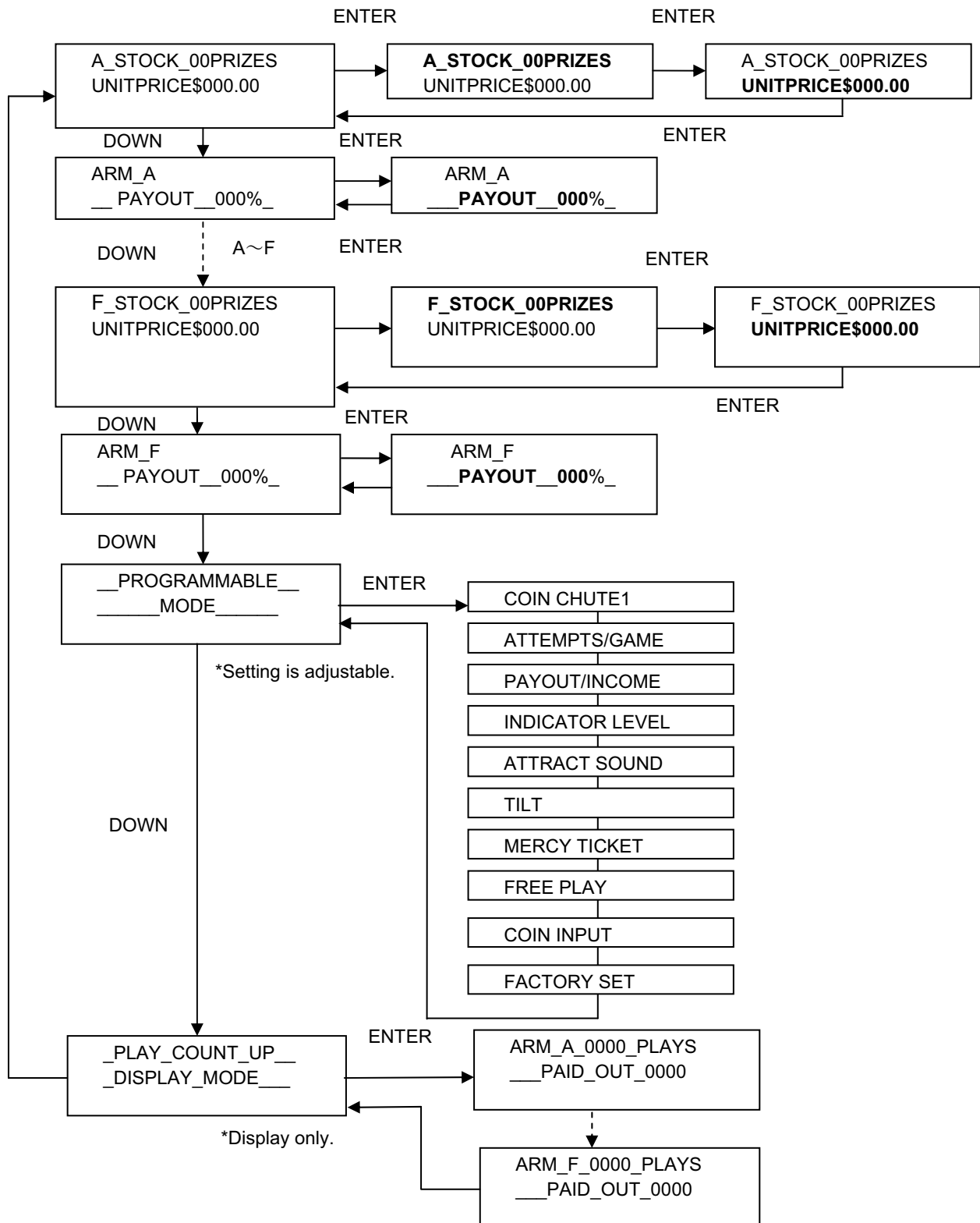

## 6.5 ADJUST PRIZE SETTING

| Mode  | Function  | LCD display *Example                  | Note   |
|---|---|---------------------------------------|--|
| PRIZE SETTING                                     | PAYOUT : ALL setting  |                                       |  |
|   | Prize Vending Arm ON, OFF individual setting.                               | A_STOCK ON<br>AVE PRICE\$000.00       | Function setting for Prize Vending Arm A to F.   |
|   | Average prize value for all arms are linked.                                |                                       | Set average prize value.   |
|   | PAYOUT : EVERY ARM setting  |                                       |  |
|   | Prize quantity and value for vending Arm "A".                               | A_STOCK_00PRIZES<br>UNITPRICE\$000.00 | Set prize quantity.<br><br>Prize value can be set as a multiplier of \$0.25.<br><br>Set each Vending Arm individually. |
| PAYOUT SETTING MODE                               | PAYOUT : ALL setting  |                                       |  |
|   | Payout setting for all Vending Arms are linked.                             | ARM_A-F<br>__ PAYOUT __ 000%_         | Payout ratio can be set as a multiplier of 5. 0 to 100.  |
|   | PAYOUT : EVERY ARM setting  |                                       |  |
|   | Arm "A" payout ratio setting<br><br>Set each Arm payout ratio individually. | ARM_A _____<br>__ PAYOUT __ 000%_     | Payout ratio can be set as a multiplier of 5. 0 to 100.<br><br>Set each Vending Arm individually.                      |
| COIN CHUTE  | Play value setting for chute 1.<br><br>Set coin (s) and credit (s).         | COIN CHUTE 1<br>_1_COIN_1CREDIT       | \$0.25 / PLAY<br>1COIN~40COINS   |
|   | Play value setting for chute 2.<br><br>Set coin (s) and credit (s).         | COIN CHUTE 2<br>_1_COIN_1CREDIT       | If "COIN INPUT" setting is set to "COMBINE", chute 2 setting will not display.   |
| PLAY COUNT AND PRIZE PAID OUT DISPLAY OF ALL ARMS | Arm "A" to "F".   | ARM_A_0000_PLAYS<br>__PAID_OUT_0000   | Display total play times and Prize paid out quantity.  |

When payout setting is "ALL", you can set Arm "OFF" at prize setting mode. This setting for you to operate the game without some Prize Vending Arms, malfunction Prize Vending Arms or prize empty. The setting for "EVERY ARM" mode, set "STOCK 00 PRIZES" does the same thing as above.

## 6.6 PROGRAMMABLE MODE

| MODE   | LCD DISPLAY                           | FEATURES  |
|--|---------------------------------------|---|
| COIN CHUTE   | COIN CHUTE 1<br><b>1</b> COIN 1CREDIT | Value of the COIN CHUTE 1.  |
|  | COIN CHUTE 2<br><b>1</b> COIN 1CREDIT | Value of the COIN CHUTE 2.<br>When COIN INPUT setting is set to "COMBINE", COIN CHUTE 2 setting will not display. |
| ATTEMPTS/GAME  | ATTEMPTS/GAME<br><b>3</b> TIMES       | Number of attempts per game.  |
| PAYOUT/INCOME  | PAYOUT/INCOME<br><b>ALL</b>           | Payout prize based on all Vending Arms average prize value setting.   |
|  | PAYOUT/INCOME<br><b>EVERY_ARM</b>     | Payout prize based on each individual vending Arms prize value setting.   |
| INDICATOR LEVEL  | INDICATOR LEVEL<br><b>CONTINUE</b>    | Remaining last play score.  |
|  | INDICATOR LEVEL<br><b>LEVEL_6</b>     | After 30 sec. of play, the game gauge lamp will be set to 6 lamps to start the game.                              |
|  | INDICATOR LEVEL<br><b>CLEAR</b>       | After 30 sec. of play, the game gauge lamp will be clear and set to 0 lamp to start game.                         |
| ATTRACT_SOUND  | ATTRACT_SOUND<br><b>ON</b>            | Turns ON or OFF attract sound and music for attract mode. The lighting effect also changes.                       |
| TILT   | TILT<br><b>ON</b>                     | Set TILT system ON or OFF.  |
| MERCY_TICKETS<br>(This setting is optional. Only if the machine is installed ticket or capsule dispenser.) | MERCY_TICKETS<br><b>OFF</b>           | No payout ticket or capsule.  |
|  | MERCY_TICKET<br><b>ONE</b>            | Payout one ticket after the game is completed.  |
|  | MERCY_TICKETS<br><b>PAID_SCORE</b>    | Payout ticket (s) same point as game score.   |
|  | MERCY_TICKET<br><b>CAPSULE</b>        | Payout one capsule after the game is completed.   |
| FREE_PLAY  | FREE_PLAY<br><b>OFF</b>               | Set free play on or off.  |
| COIN INPUT   | COIN INPUT<br><b>COMBINE</b>          | Adjust coin signal for chute 1 and 2 combine or not.  |
|  | COIN INPUT<br>A:25 ¢ B: <b>25 ¢</b>   | Set coin chute 1 for 25 ¢, coin chute 2 for 25 ¢. These count coin settings are set separately.                   |
|  | COIN INPUT<br>A:25 ¢ B: <b>50 ¢</b>   | Set coin chute 1 for 25 ¢, coin chute 2 for 50 ¢. These count coin settings are set separately.                   |
|  | COIN INPUT<br>A:25 ¢ B: <b>\$1</b>    | Set coin chute 1 for 25 ¢, coin chute 2 for \$1. These count coin settings are set separately.                    |
| FACTORY SET  | FACTORY SET<br><b>ON OFF</b>          | Set factory default setting.  |

## 6.7 FACTORY DEFAULT SETTING

Enter FACTORY SET at PROGRAMMABLE MODE, then select ON to set to factory setting.

| MODE                            | LCD DISPLAY                                   | NOTE  |
|---------------------------------|---|---|
| A_STOCK ON<br>AVE PRICE\$060.00 | <b>A_STOCK ON</b><br><b>AVE PRICE\$060.00</b> | All Arms A-F are ON.<br>Average price value is \$60.                                  |
| ARM A-F<br>PAYOUT 025%          | <b>ARM A-F</b><br><b>PAYOUT 025%</b>          | Payout ratio 25% for total Arms A-F.  |
| COIN CHUTE                      | COIN CHUTE 1<br><b>4COIN 1CREDIT</b>          | 4 coins 1 credit.   |
| ATTEMPTS/GAME                   | ATTEMPTS/GAME<br><b>3 TIMES</b>               | 1 credit attempt 3 times play.  |
| PAYOUT/INCOME                   | PAYOUT/INCOME<br><b>ALL</b>                   | Payout prize based on all Vending Arms average prize value setting.                   |
| INDICATOR LEVEL                 | INDICATOR LEVEL<br><b>CONTINUE</b>            | Remaining last play score.  |
| ATTRACT_SOUND                   | ATTRACT_SOUND<br><b>ON</b>                    | Play attract sound and music for attract mode. The lighting effect is also activated. |
| TILT                            | TILT<br><b>ON</b>                             | Tilt sensor ON.   |
| MERCY_TICKETS                   | MERCY_TICKETS<br><b>OFF</b>                   | No dispense ticket or capsule.  |
| FREE_PLAY                       | FREE_PLAY<br><b>OFF</b>                       | Free play OFF.  |
| COIN INPUT                      | COIN INPUT<br><b>COMBINE</b>                  | Combine coin signal for chute 1 and 2.  |

## 7.0 PRIZES

### 7.1 RECOMMENDED PRIZE SIZES

MAXIMUM:

Height: 11" (280mm) \*Including hanging tie.

Width: 7" (18mm)

Depth: 4" (100mm)

Weight: 10.5 oz (300g)

#### CAUTION

USING PRIZES OF THE FOLLOWING RECOMMENDED SIZE WILL PREVENT THE MACHINE FROM MALFUNCTIONING.

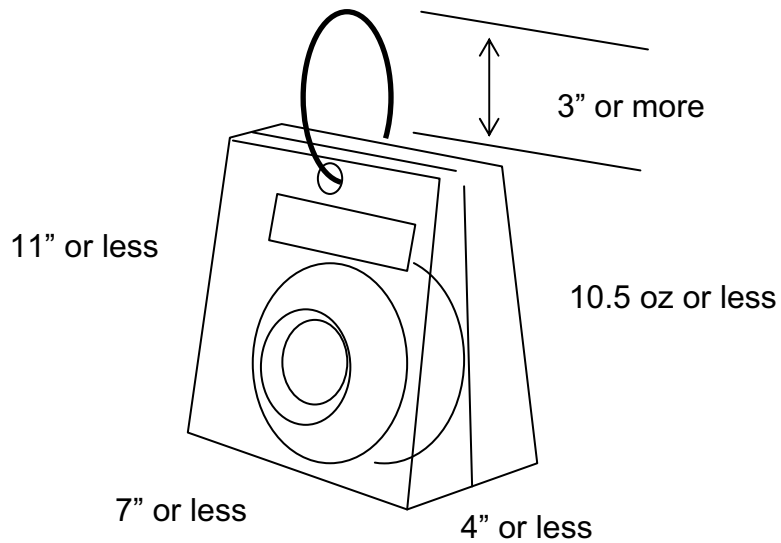

## 7.2 HOW TO FILL THE PRIZES

Step 1: Remove Prize Lock Shaft.

- 1) Unscrew the Prize Lock Shaft. (Counter clockwise direction)
- 2) Remove the shaft by pulling it all the way out.

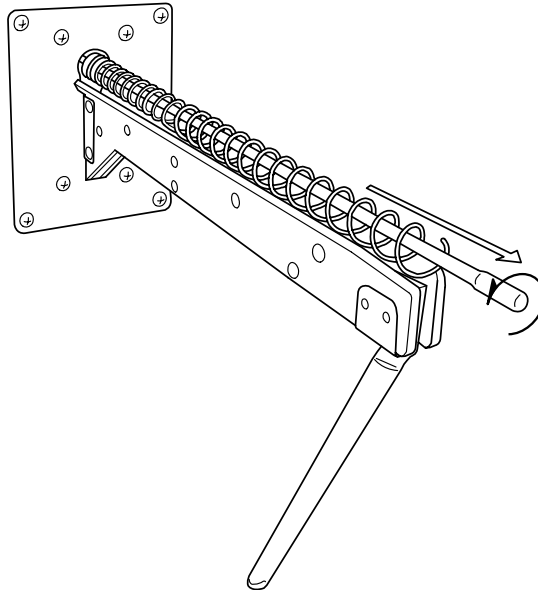

Step 2: Loading the prizes.

- 1) Load the prize by sliding the hanging tie over the entire arm.
- 2) Make sure the bottom of the prize is not touching the Prize Vending Arm below.

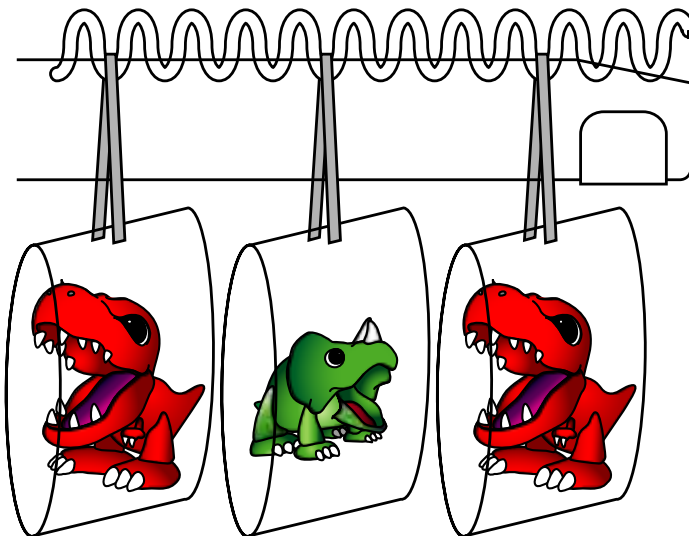

Step 3: Correct positioning of prizes.

- 1) Position the hanging tie on the prize arm.
- 2) Make sure enough space is between prizes to show the customer.

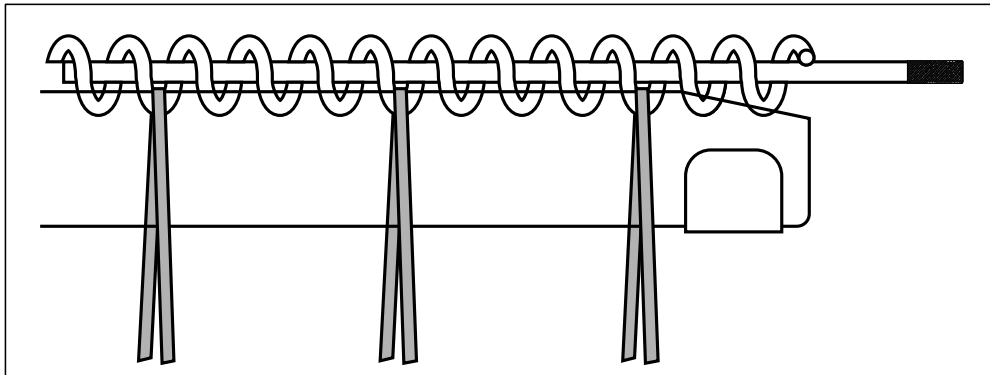

Step 4: Reinstall Prize Lock Shaft.

- 1) Reinsert the Prize Lock Shaft by positioning it in the center of the Spiral. Make sure the Prize Lock Shaft always stays above the hanging ties.
- 2) Tighten the Prize Lock Shaft. (Clockwise direction)

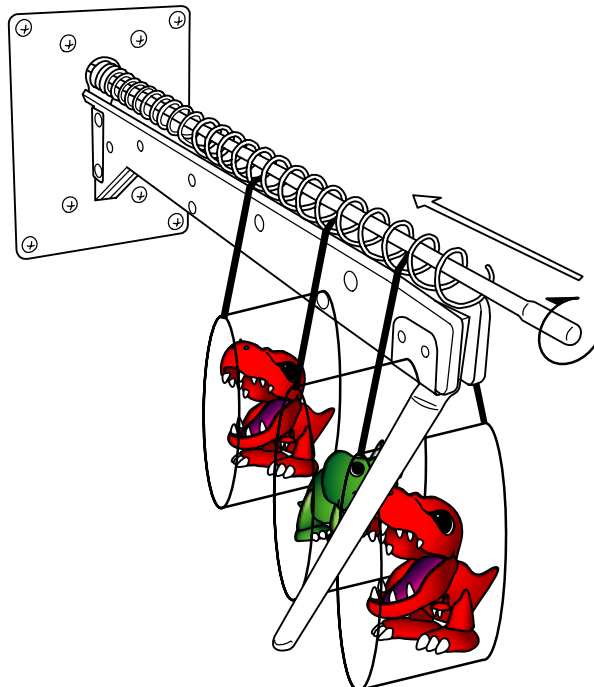

### 7.3 ADJUSTING THE PRIZE SLIDE GUIDE

Adjust positioning of prize slide guide.

- 1) Loosen the Phillips screw under the Prize Arm. (See picture below.)
- 2) Position all the Prize slide guides toward the center of the game.( See picture below.)
- 3) Tighten the screw that you loose under the Prize Arm.
- 4) Make sure the prize will not drop on to the Roulette unit.

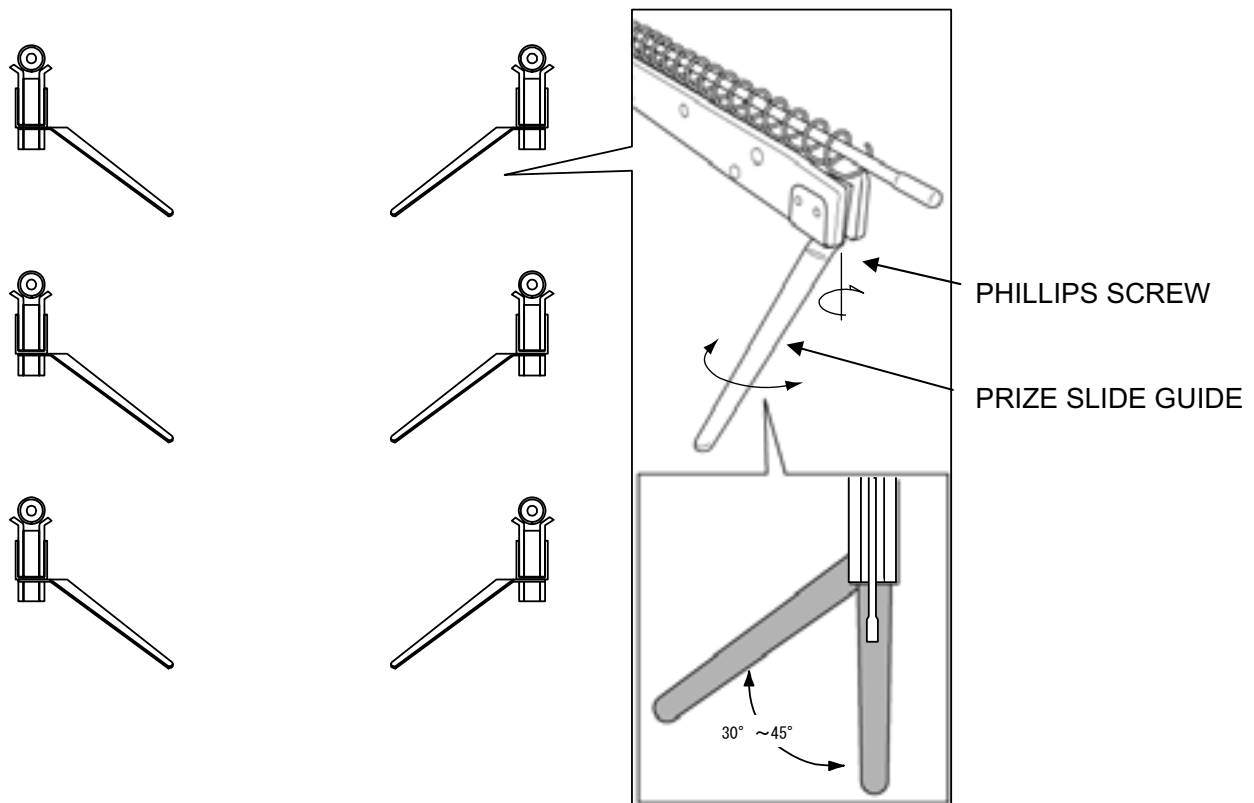

## 8.0 OPERATE WITHOUT PRIZE VENDING ARM

If you wish to operate the game with large size of the prizes, you can disable and remove the Prize Vending Arm unit.

**NOTE: YOU MUST CHANGE THE PRIZE PAYOUT SETTING AFTER YOU REMOVE THE PRIZE VENDING ARM UNIT. (See the Prize setting on page 11)**

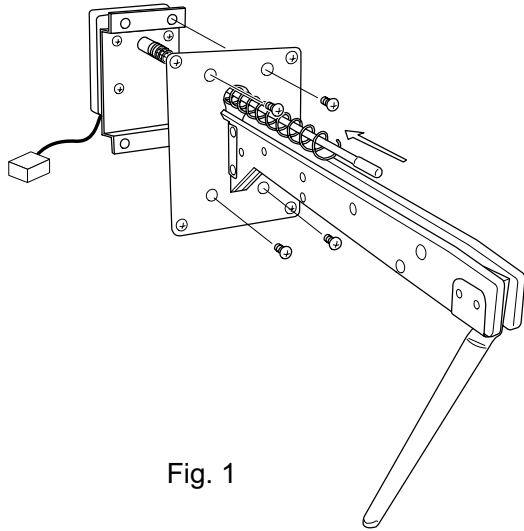

Fig. 1

Step 1: Remove Prize Motor.

- 1) Unscrew 4 position of the Phillips screws. (See Fig.1)
- 2) Unplug and remove the motor unit from back of the game.

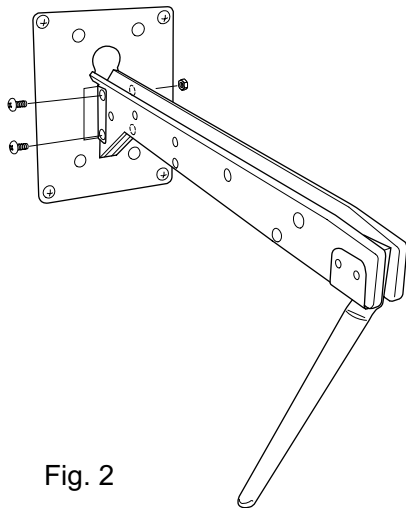

Fig. 2

Step 2: Remove Prize Arm.

- 1) Unscrew 2 position of the Phillips screws. (See Fig.2)
- 2) Remove the Prize Arm. (See Fig.3)

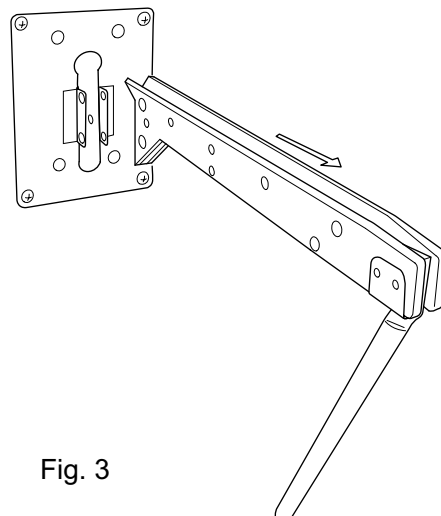

Fig. 3

## 9.0 TEST MODE

### 9.1 HOW TO START TEST MODE

Press the TEST switch to enter TEST MODE. Press the TEST switch again to move to each mode.

### 9.2 LAMP TEST MODE

When you enter Lamp test mode, lamps will do the following.

- Halogen light and “GET” lamps will flash on and off.
- Gauge lamps will flash on and off from the bottom to top.
- Prize select lamps will flash on and off.
- All “TO PLAY’ lamps will flash on and off.
- Prize select button lamp and Brake button lamp will flash on and off.
- LED will count up from 00 to 99.

### 9.3 SENSOR AND SWITCH TEST MODE

The sensor and switch activation will be shown on the LED display at the Control panel.

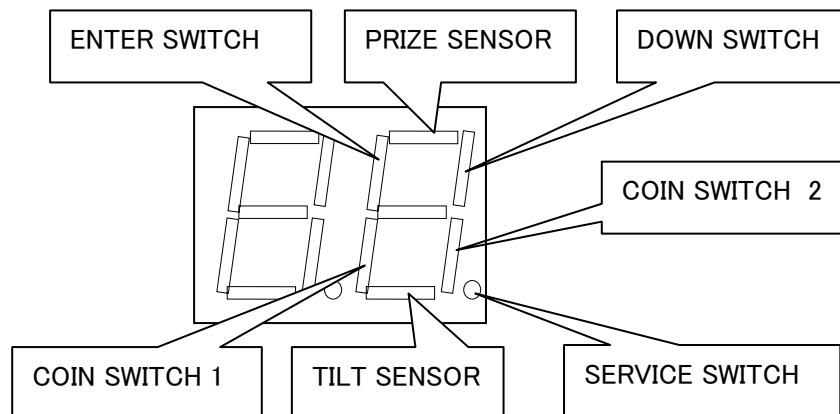

Press the Brake or Prize select Button to flash the lamp to check the activation of switches.

#### **9.4 SOUND TEST MODE**

Use Prize select or Brake button to change sound code. Press the ENTER button to play sound or music.

#### **9.5 MECHANICAL TEST MODE**

A: Stepping motor test.

When you enter this mode, the first digit of the LED display shows "S". Press the Prize select button to start rotating the stepping motor. Press the Brake button to stop the stepping motor.

B: Prize Vending Arm motor test.

When you enter this mode, the first digit of the LED display shows "P" and the second digit shows the location of the Prize Arm.

Press the Prize select button to start rotating the Arm motor. Press the Brake button to move to the next Prize Arm.

C: Ticket or Capsule dispenser test.

This test mode is optional.

## 10.0 PAYOUT DATA CLEAR

You can Clear Paid out prize quantity and Play count data by the following:

### **WARNING**

**Once you cleared Payout data, the data is completely deleted from the machine.**

### 10.1 CLEAR EACH PRIZE ARM PAYOUT DATA

Press the DOWN switch on the service panel inside of the Coin Door to enter the PLAY COUNT UP DISPLAY MODE. Press ENTER switch to display current data on the LCD display. (See example chart below)

|                                     |               |
|-------------------------------------|---------------|
| ARM_A_0000_PLAYS<br>__PAID_OUT_0000 | Example Chart |
|-------------------------------------|---------------|

Press the Down switch to select the Arm you wish to clear Payout data. Press and hold the Brake button, then press and hold the ENTER switch for more then 3 sec. The data will be cleared.

### 10.2 CLEAR ALL PRIZE ARM PAYOUT DATA

Press the DOWN switch on the service panel inside of the Coin Door to enter the PLAY COUNT UP DISPLAY MODE. Press the ENTER switch to display current data on the LCD display. (See example chart below)

|                                     |               |
|-------------------------------------|---------------|
| ARM_A_0000_PLAYS<br>__PAID_OUT_0000 | Example Chart |
|-------------------------------------|---------------|

Press and hold the Prize select button, then press and hold the ENTER switch for more then 3 sec. The data will be cleared.

## 11.0 ERROR MESSAGE CHART

| DISPLAY SHOWS | Cause of problem and solution.   |
|---------------|--|
| H             | <u>Service switch error</u><br>This error code appears when the Service switch is kept on after powering the game. Check the switch for continuity.  |
| E             | <u>Coin switch 1 error</u><br>Check the Coin Mech for any jamming of coins or tokens. Correct and re-power the game.   |
| F             | <u>Coin switch 2 error</u><br>Check the Coin Mech for any jamming of coins or tokens. Correct and re-power the game.   |
| S             | <u>Prize sensor error</u><br>Check the prize drop chute for any blockage. Check sensor activation at the switch and sensor test mode.  |
| A             | <u>Wheel motor error</u><br>This error code appears when the stepping motor for the Wheel is not reading signals. Check stepping motor by mechanical test mode.  |
| b             | <u>Prize Arm A motor time out error</u><br>This error code appears when the prize sensor does not sense after sending signal to the motor to rotate. (App. 25 sec.) Check the prize motor by mechanical test mode. |
| C             | <u>Prize Arm B motor time out error</u><br>This error code appears when the prize sensor does not sense after sending signal to the motor to rotate. (App. 25 sec.) Check the prize motor by mechanical test mode. |
| d             | <u>Prize Arm C motor time out error</u><br>This error code appears when the prize sensor does not sense after sending signal to the motor to rotate. (App. 25 sec.) Check the prize motor by mechanical test mode. |
| G             | <u>Prize Arm D motor time out error</u><br>This error code appears when the prize sensor does not sense after sending signal to the motor to rotate. (App. 25 sec.) Check the prize motor by mechanical test mode. |
| L             | <u>Prize Arm E motor time out error</u><br>This error code appears when the prize sensor does not sense after sending signal to the motor to rotate. (App. 25 sec.) Check the prize motor by mechanical test mode. |
| n             | <u>Prize Arm F motor time out error</u><br>This error code appears when the prize sensor does not sense after sending signal to the motor to rotate. (App. 25 sec.) Check the prize motor by mechanical test mode. |
| P             | <u>Prize empty error</u><br>Refill prize and adjust the prize quantity by "Prize Setting mode".  |
| T             | <u>Tilt error</u><br>Check Tilt sensor. If sensor shaft keeps touching the sense bracket error will always occur.  |
| r             | <u>EEPROM error</u><br>Data writing error. Try re-powering the game. If error is not cleared, you may need to exchange the Main PCB.   |
| U             | <u>RAM error</u><br>RAM error. Try re-powering the game. If error is not cleared, you may need to exchange the Main PCB.   |
| J             | <u>Ticket dispenser error</u><br>OPTIONAL  |
| J             | <u>Capsule dispenser error</u><br>OPTIONAL   |

NOTE: The prize motor time out error will appear only if the setting is "EVERY\_ARM" at PAYOUT/INCOME setting mode. For "ALL" setting, these error messages will not appear.

## 12.0 TECHNICAL REFERENCE

| Parts description                                     | Parts number |
|---|--------------|
| Convoy Main CPU Board                                 | K11T0993A    |
| LED Board   | K91X0864A    |
| Sensor Board (Send & Receive)                         | K91X0645C    |
| LCD Board   | K91X0980A    |
| Prize DC Motor  | C1200533A    |
| Roulette Stepper Motor                                | C1200532A    |
| Photo Sensor (For Roulette Assy)                      | A9000490A    |
| Power Supply 120V 200W                                | CVE0001A     |
| Speaker 8ohm 5W                                       | CVE0002A     |
| Brake Button Assy, Red                                | CVE0003A     |
| Prize Select Button Assy, Yellow                      | CVE0004A     |
| Coin Meter 12V  | CVE0005A     |
| Potentiometer 5W 100 Ohm                              | CVE0006A     |
| Solid State Relay Input 3-15VDC Output Max 240VAC 18A | CVE0007A     |
| Wedge Lamps #161 12V 0.2A                             | CVE0008A     |
| Halogen Lamp 120V 50W Flood                           | CVE0009A     |
| Fluorescent Lamp 120V 20W 12T CW                      | CVE0010A     |
| Starter FS-2  | CVE0011A     |
| Convoy Play Instruction Decal                         | CVG0001A     |
| Convoy Marquee  | CVG0002A     |
| Convoy Roulette Decal                                 | CVG0003A     |
| Convoy Operating Manual                               | CVG0004A     |
| Prize Pickup Door                                     | CVP0130A     |
| Speaker Plate   | CVM0144A     |
| Glass Door Latch                                      | CVM0250A     |
| Glass Door Assy                                       | CVU0001A     |
| Prize Arm Assy w/o Motor Assy                         | CVU0002A     |
| Truck Arrow Assy                                      | CVU0003A     |
| Leg leveler   | CVM9001A     |
| Caster  | CVM9002A     |

## WARRANTY

Seller warrants that its printed circuit boards and parts thereon are free from defects in materials and workmanship under normal use and service for a period of ninety (90) days from the date of shipment. Seller warrants that its video displays (in games supplied with video displays) are free from defects in material and workmanship under normal use and service for a period of thirty (30) days from the date of shipment. None of the Seller's other products or parts thereof are warranted. Seller's sole liability shall be, at its option, to repair, replace, or credit Buyer's account for such products which are returned to Seller during said warranty period, provided:

- a) Seller is promptly notified in writing upon discovery by Buyer that said products are defective.
- b) Such products are returned prepaid to Seller's plant; and
- c) Seller's examination of said products discloses to Seller's satisfaction that such alleged defects existed and were not caused by accident, misuse, neglect, alteration, improper repair, improper installation, or improper testing.

In no event shall Seller be liable for loss of profits, loss of use, incidental or consequential damages.

Except for any express warranty set forth in a written contract between Seller and Buyer which contract supersedes the terms herein, this warranty is in lieu of all other warranties expressed or implied, including the implied warranties of merchantability and fitness for a particular purpose, and all other obligations or liabilities on the Seller's part, and it neither assumes nor authorizes any other person to assume for the Seller any other liabilities in connection with the sale of products by Seller.

**Namco America Inc.** distributors are independent, being privately owned and operated. In their judgment they may sell parts or accessories other than **Namco America Inc.** parts or accessories. **Namco America Inc.** cannot be responsible for the quality, suitability or safety of any non-**Namco America Inc.** part or any modification including labor, which is performed by such distributor.

## SERVICE

If you have questions regarding any **Namco America Inc.** product or require technical support:

Contact **Namco America Inc.** Customer Service at:

1 (408) 383-3973 or FAX (408) 436-9554

Hours: 8:00 am - 4:00 pm PDT

Parts and repair services for **Namco America Inc.** products are available through your distributor.